

imc CRONOSflex

Getting Started

Edition 13 - 2024-04-22



Disclaimer of liability

The contents of this documentation have been carefully checked for consistency with the hardware and software systems described. Nevertheless, it is impossible to completely rule out inconsistencies, so that we decline to offer any guarantee of total conformity.

We reserve the right to make technical modifications of the systems.

Copyright

© 2024 imc Test & Measurement GmbH, Germany

This documentation is the intellectual property of imc Test & Measurement GmbH. imc Test & Measurement GmbH reserves all rights to this documentation. The applicable provisions are stipulated in the "imc Software License Agreement".

The software described in this document may only be used in accordance with the provisions of the "imc Software License Agreement".

Open Source Software Licenses

Some components of imc products use software which is licensed under the GNU General Public License (GPL). Details are available in the About dialog.

A list of the open source software licenses for the imc measurement devices is located on the imc STUDIO/imc WAVE/imc STUDIO Monitor installation medium in the folder "*Products\imc DEVICES\OSS*" or "*Products\imc DEVICEcore\OSS*" or "*Products\imc STUDIO\OSS*". If you wish to receive a copy of the GPL sources used, please contact our tech support.

Notes regarding this document

This document is an excerpt from the manual of the device / the module.

This document provides important notes on using the device / the module. Safe working is conditional on compliance with all safety measures and instructions provided. The manual is to be used as a kind of reference book. You can skip the description of the modules you do not have.

Additionally, all accident prevention and general safety regulations pertinent to the location at which the device is used must be adhered to.

These instructions exclusively describe the device, **not how to operate** it by means of **the software!**

If you have any questions as to whether you can set up the device / module in the intended environment, please contact our tech support. The measurement system has been designed, manufactured and unit-tested with all due care and in accordance with the safety regulations before delivery and has left the factory in perfect condition. In order to maintain this condition and to ensure safe operation, the user must observe the notes and warnings contained in this chapter and in the specific sections applicable to the concrete device. Never use the device outside the specification.

This will protect you and prevent damage to the device.

Special notes

Warning

Warnings contain information that must be observed to protect the user from harm or to prevent damage to property.

Note

Notes denote useful additional information on a particular topic.

Reference

A reference in this document is a reference in the text to another text passage.

Table of contents

1 General introduction	6
1.1 Tech support	6
1.2 Service and maintenance	6
1.3 Legal notices	6
1.4 Explanation of symbols	9
1.5 Last changes in content	10
2 Safety	11
3 Assembly and connection	14
3.1 After unpacking...	14
3.2 Before commissioning	14
3.3 Precautions for operation	15
3.4 Attachment mechanism	16
3.5 Signal connection	17
3.6 imc CRONOSflex Description of the system	18
3.6.1 Building Block Principle Maximizes Flexibility	18
3.6.2 System bus	18
3.6.3 Modular components "click" together	18
3.6.4 Distributed measurement system	18
3.7 Networking and power supply	19
3.8 Main switch	21
3.8.1 Remote control of the main switch	21
3.9 Power over EtherCAT (PoEC)	21
3.10 Storage media in the device	21
3.10.1 For devices of the firmware group A (imc DEVICES)	22
3.11 Saving data in case of power outage	30
3.12 Stabilized device supply and UPS (Power Handle)	31
3.12.1 Li-Ion batteries	31
3.13 Isolation and grounding concept	33
3.13.1 Isolation	33
3.13.2 Grounding concept	34
3.14 Power supply options (CRFX)	35
3.14.1 Overview of power supply options	35
3.14.2 Rules governing supply configurations	36
3.14.3 Directly stacked modules	37
3.14.4 Overall system consisting of multiple blocks	38
3.14.5 Supplemental device power supply (Power Handle)	39
3.14.6 Overview of available operation and remote control modes	40
3.14.7 Charging the internal battery of a Power-Handle having UPS-functionality	41
3.14.8 Power over EtherCAT operation	43
3.15 Overview power consumption	44
3.16 Internal system-bus: Network cables	45
3.17 CRFX/ETHERCAT-GATEWAY	46
3.17.1 Application	46
3.17.2 Configuration via imc STUDIO	47
4 Maintenance and servicing	48
4.1 Maintenance and servicing	48

4.2 Cleaning	48
4.3 Storage	48
4.4 Transport	48
5 Start of operation Software / Firmware	49
5.1 Installation - Software	49
5.1.1 System requirements	49
5.2 Connect the device	49
5.3 Connecting via LAN in three steps	50
5.4 Firmware update	53
6 Pin configuration	56
6.1 DSUB-15 pin configuration	56
6.1.1 Universal plug	57
6.1.2 Standard plug	57
6.1.3 Special plug	58
6.1.4 TEDS plug	59
6.2 DSUB-26 pin configuration (High Density)	60
6.3 DSUB-37 pin configuration	60
6.4 LEMO pin configuration	61
6.4.1 LEMO.1B (7-pin)	61
6.4.2 LEMO.1B (4-pin)	62
6.4.3 LEMO.1E (6-pin), WFT-2	62
6.4.4 LEMO.1S (3-pin), ACI-8	62
6.4.5 LEMO.1P (5-pin), HISO-8-L	63
6.4.6 LEMO.2P (2-pin), HISO-8-T-8L	63
6.4.7 LEMO.2P (8-pin), HISO-8-T-2L	63
6.4.8 REMOTE plug (female)	63
6.5 DSUB-9 pin configuration	64
6.5.1 Display	64
6.5.2 GPS receiver	64
6.5.3 SEN-SUPPLY-4	64
6.5.4 APPMOD	65
6.5.5 CAN, CAN FD	65
6.5.6 LIN-Bus	65
6.5.7 PROFIBUS	65
6.5.8 FlexRay	66
6.5.9 MVB-Bus	67
6.5.10 ARINC	68
6.6 PROFINET	69
6.7 EtherCAT	69
Index	70

1 General introduction

1.1 Tech support

If you have problems or questions, please contact our tech support:

Phone: (Germany): **+49 30 467090-26**
E-Mail: hotline@imc-tm.de
Internet: <https://www.imc-tm.com/service-training/>

Tip for ensuring quick processing of your questions:

If you contact us **you would help us**, if you know the **serial number of your devices** and the **version info of the software**. This documentation should also be on hand.

- The device's serial number appears on the nameplate.
- The program version designation is available in the About-Dialog.

Product Improvement and change requests

Please help us to improve our documentation and products:

- Have you found any errors in the software, or would you suggest any changes?
- Would any change to the mechanical structure improve the operation of the device?
- Are there any terms or explanations in the manual or the technical data which are confusing?
- What amendments or enhancements would you suggest?

Our [tech support](#) will be happy to receive your feedback.

1.2 Service and maintenance

Our service team is at your disposal for service and maintenance inquiries:

E-Mail: service@imc-tm.de
Internet: <https://www.imc-tm.com/service>

Service and maintenance activities include, for example calibration and adjustment, service check, repairs.

1.3 Legal notices

Quality Management



imc Test & Measurement GmbH holds DIN EN ISO 9001 certification since May 1995 and DIN EN ISO 14001 certification since November 2023. You can download the CE Certification, current certificates and information about the imc quality system on our website:

<https://www.imc-tm.com/quality-assurance/>.

imc Warranty

Subject to the general terms and conditions of imc Test & Measurement GmbH.

Liability restrictions

All specifications and notes in this document are subject to applicable standards and regulations, and reflect the state of the art well as accumulated years of knowledge and experience. The contents of this document have been carefully checked for consistency with the hardware and the software systems described. Nevertheless, it is impossible to completely rule out inconsistencies, so that we decline to offer any guarantee of total conformity. We reserve the right to make technical modifications of the systems.

The manufacturer declines any liability for damage arising from:

- failure to comply with the provided documentation,
- inappropriate use of the equipment.

Please note that all properties described refer to a closed measurement system and not to its individual slices.

Guarantee

Each device is subjected to a 24-hour "burn-in" before leaving imc. This procedure is capable of detecting almost all cases of early failure. This does not, however, guarantee that a component will not fail after longer operation. Therefore, all imc devices are granted liability for a period of two years. The condition for this guarantee is that no alterations or modifications have been made to the device by the customer.

Unauthorized intervention in the device renders the guarantee null and void.

Notes on radio interference suppression

Devices of the imc CRONOS system family satisfy the EMC requirements for an use in industrial settings.

Any additional products connected to the product must satisfy the EMC requirements as specified by the responsible authority (within Europe¹) in Germany the BNetzA - "Bundesnetzagentur" (formerly BMPT-Vfg. No. 1046/84 or No. 243/91) or EC Guidelines 2014/30/EU. All products which satisfy these requirements must be appropriately marked by the manufacturer or display the CE certification marking.

Products not satisfying these requirements may only be used with special approval of the regulating body in the country where operated.

All lines connected to the devices of the imc CRONOS system family should not be longer than 30 m and they should be shielded and the shielding must be grounded.

Note

The EMC tests were carried out using shielded and grounded input and output cables with the exception of the power cord. Observe this condition when designing your setup to ensure high interference immunity and low jamming.

¹ If you are located outside Europe, please refer the appropriate EMC standards used in the country of operation.

Cables and leads

In order to comply with the value limits applicable to Class B devices according to part 15 of the FCC regulations, all signal leads connected to devices of the imc CRONOS system family must be shielded.

Unless otherwise indicated, no connection leads may be long leads (< 30 m) as defined by the standard IEC 61326-1. LAN-cables (RJ 45) and CAN-Bus cables (DSUB-9) are excepted from this rule.

Only cables with suitable properties for the task (e.g. isolation for protection against electric shock) may be used.

ElektroG, RoHS, WEEE, CE

The imc Test & Measurement GmbH is registered with the authority as follows:

WEEE Reg. No. DE 43368136

valid from 24.11.2005



Reference

<https://www.imc-tm.com/elekrog-rohs-weee/> and <https://www.imc-tm.com/ce-conformity/>

FCC-Notice

This product has been tested and found to comply with the limits for a Class B digital device, pursuant to Part 15 of the FCC Rules. These limits are designed to provide reasonable protection against harmful interference in a residential installation. This equipment generates, uses, and can radiate radio frequency energy and, if not installed and used in accordance with the instructions, may cause harmful interference to radio communications. However, there is no guarantee that interference will not occur in a particular installation. If this equipment does cause harmful interference to radio or television reception, which can be determined by turning the equipment on and off, the user is encouraged to try to correct the interference by one or more of the following measures:

- Reorient or relocate the receiving antenna.
- Increase the separation between the equipment and the receiver.
- Connect the equipment into an outlet on a circuit different from that to which the receiver is connected.
- Consult our tech support or an experienced technician for help.

Modifications

The FCC requires the user to be notified that any changes or modifications made to this product that are not expressly approved by imc may void the user's authority to operate this equipment.

1.4 Explanation of symbols



CE Conformity

see CE [chapter 1.2](#)



No household waste

Please do not dispose of the electrical/electronic device with household waste, but at the appropriate collection points for electrical waste, see also [chapter 1.2](#).



Potential compensation

Connection for potential compensation



Grounding

Connection for grounding (general, without protective function)



Protective connection

Connection for the protective conductor or grounding with protective function



Attention! General danger zone!

This symbol indicates a dangerous situation; Since there is insufficient space for indicating the rated quantity at the measuring inputs, refer to this manual for the rated quantities of the measuring inputs before operation.



Attention! Injuries from hot surfaces!

Surfaces whose temperatures can exceed the limits under certain circumstances are denoted by the symbol shown at left.



ESD-sensitive components (device/connector)

When handling unprotected circuit boards, take suitable measures to protect against ESD (e.g. insert/remove ACC/CANFT-RESET).



Possibility of electric shock

The warning generally refers to high measurement voltages or signals at high potentials and is located on devices suitable for such measurements. The device itself does not generate dangerous voltages.



DC, Direct Current

Supply of the device via a DC voltage source (in the specified voltage range)



RoHS of the PR China

The limits for hazardous substances in electrical/electronic equipment applicable in the PRC are identical to those in the EU. The restrictions are complied with (see [chapter 1.2](#)⁶). A corresponding "China-RoHS" label is omitted for formal/economic reasons. Instead, the number in the symbol indicates the number of years in which no hazardous substances are released. (This is guaranteed by the absence of named substances).



Labeling integrated energy sources

UxxRxx are integrated in the symbolism. "U" stands for the installed UPS energy sources, if 0 = not installed. "R" stands for the installed RTC energy sources, if 0 = not installed. You can download the corresponding data sheets from the imc website:

<https://www.imc-tm.com/about-imc/quality-assurance/transport-instructions/>



Observe the documentation

Read the documentation before starting work and/or operating.



On/Off

On/Off button (no complete disconnection from the power supply)

1.5 Last changes in content

Amendments and bug-fix in imc CRONOSflex - Getting Started, Edition 13

Section	Amendments
General	We have replaced the name "Hotline" with the name "Technical Support".
Storage media ²¹	updated description of recommended handling

Amendments and bug-fix in imc CRONOSflex - Getting Started, Edition 12

Section	Amendments
Symbols	new battery labeling on the name plate added
EtherCAT-GATEWAY ⁴⁶	description of the bus coupler added

Amendments and bug-fix in imc CRONOSflex - Getting Started, Edition 11

Section	Amendments
EtherCAT ⁶⁹	FAQ concerning transmission of Power over EtherCAT added

2 Safety

This section provides an overview of all important aspects of protection of the users for reliable and trouble-free operation. Failure to comply with the instructions and protection notes provided here can result in serious danger.

Responsibility of the operator

Devices of the imc CRONOS system family are for use in commercial applications. The user is therefore obligated to comply with legal regulations for work safety.

Along with the work safety procedures described in this document, the user must also conform to regulations for safety, accident prevention and environmental protection which apply to the work site. If the product is not used in a manner specified by the manufacturer, the protection supported by the product may be impaired.

The user must also ensure that any personnel assisting in the use of the devices of the imc CRONOS system family have also read and understood the content of this document.

Operating personnel

This document identifies the following qualifications for various fields of activity:

- *Users of measurement engineering*: Fundamentals of measurement engineering. Basic knowledge of electrical engineering is recommended. Familiarity with computers and the Microsoft Windows operating system. Users must not open or structurally modify the measurement device.
- *Qualified personnel* are able, due to training in the field and to possession of skills, experience and familiarity with the relevant regulations, to perform work assigned while independently recognizing any hazards.

Warning

- **Danger of injury due to inadequate qualifications!**
- Improper handling may lead to serious damage to personnel and property. When in doubt, consult qualified personnel.
- Work which may only be performed by trained imc personnel may not be performed by the user. Any exceptions are subject to prior consultation with the manufacturer and are conditional on having obtained corresponding training.

Special hazards

This segment states what residual dangers have been identified by the hazard analysis. Observe the safety notes listed here and the warnings appearing in subsequent chapters of this manual in order to reduce health risks and to avoid dangerous situations. Existing ventilation slits on the sides of the device must be kept free to prevent heat accumulation inside the device. Please operate the device only in the intended position of use if so specified.

Danger



Lethal danger from electric current!

- Contact with conducting parts is associated with immediate lethal danger.
- Damage to the insulation or to individual components can be lethally dangerous.

Therefore:

- In case of damage to the insulation, immediately cut off the power supply and have repair performed.
- Work on the electrical equipment must be performed exclusively by expert electricians.
- During all work performed on the electrical equipment, it must be deactivated and tested for static potential.

Injuries from hot surfaces!



- Devices from imc are designed so that their surface temperatures do not exceed limits stipulated in EN 61010-1 under normal conditions.

Therefore:

- Surfaces whose temperature can exceed the limits under circumstances are denoted by the symbol shown at left.

Industrial safety

We certify that imc CRONOS systems in all product configuration options corresponding to this documentation conforms to the directives in the accident prevention regulations in "Electric Installations and Industrial Equipment" (DGUV Regulation 3)*. This confirmation applies exclusively to devices of the imc CRONOS system family, but not to all other components included in the scope of delivery.

This certification has the sole purpose of releasing imc from the obligation to have the electrical equipment tested prior to first use (§ 5 Sec. 1, 4 of DGUV Regulation 3). This does not affect guarantee and liability regulations of the civil code.

For repeat tests, a test voltage that is 1.5 times the specified working voltage should be used to test the isolation for the highly isolated inputs (e.g. measurement inputs for high-voltage applications).

* previously BGV A3.

Observe notes and warnings

Devices from imc have been carefully designed, assembled and routinely tested in accordance with the safety regulations specified in the included certificate of conformity and has left imc in perfect operating condition. To maintain this condition and to ensure continued danger-free operation, the user should pay particular attention to the remarks and warnings made in this chapter. In this way, you protect yourself and prevent the device from being damaged.

Read this document before turning on the device for the first time carefully.

Warning

Before touching the device sockets and the lines connected to them, make sure static electricity is diverted to ground. Damage arising from electrostatic discharge is not covered by the warranty.

3 Assembly and connection

3.1 After unpacking...

Check the delivered system immediately upon receiving it for completeness and for possible transport damage. In case of damage visible from outside, proceed as follows:

- Do not accept the delivery or only accept it with reservations
- Note the extent of the damage on the packing documents or on the delivery service's packing list.
- Begin the claims process.

Please check the device for mechanical damage and/ or loose parts after unpacking it. The supplier must be notified immediately of any transportation damage! Do not operate a damaged device!

Check that the list of accessories is complete (product package):

- AC/DC-power adaptor with cable and pre-assembled plug
- LEMO plug for DC-powering
- Getting started with your imc measurement device (printed)



Note

File a claim about every fault as soon as it is detected. Claims for damages can only be honored within the stated claims period.

3.2 Before commissioning

Condensation may form on the circuit boards when the device is moved from a cold environment to a warm one. In these situations, always wait until the device warms up to room temperature and is completely dry before turning it on. The acclimatization period should take about 2 hours. This is especially recommended for devices without ET (extended environmental temperature range).

We recommend a warm-up phase of at least 30 min prior to measure.

Existing ventilation slits (e.g. CRFX modules) must be kept unimpeded to avoid heat buildup in the device interior.

Ambient temperature

The limits of the ambient temperature cannot be strictly specified because they depend on many factors of the specific application and environment, such as air flow/convection, heat radiation balance in the environment, contamination of the housing / contact with media, mounting structure, system configuration/single or block (click), connected cables, operating mode, etc. This is taken into account by specifying the operating temperature instead. Furthermore, it is not possible to predict any sharp limits for electronic components. Basically, reliability decreases when operating under extreme conditions (forced ageing). The operating temperature data represent the extreme limits at which the function of all components can still be guaranteed.

3.3 Precautions for operation

Certain ground rules for operating the system, aside from reasonable safety measures, must be observed to prevent danger to the user, third parties, the device itself and the measurement object. These are the use of the system in conformity to its design, and the refraining from altering the system, since possible later users may not be properly informed and may ill-advisedly rely on the precision and safety promised by the manufacturer.

Note

If you determine that the device cannot be operated in a non-dangerous manner, then the device is to be immediately taken out of operation and protected from unintentional use. Taking this action is justified under any of the following conditions:

- the device is visibly damaged,
- loosed parts can be heard within the device,
- the device does not work,
- the device has been stored for a long period of time under unfavorable conditions (e.g. outdoors or in high-humidity environments).

1. Observe the data in the chapter "Technical specifications" and the application hints about the individual system in order to prevent damage to the unit through inappropriate signal connection.
2. Note when designing your experiments that all input and output leads must be provided with shielding which is connected to the ground ("CHASSIS") at one end in order to ensure high resistance to interference and noisy transmission.
3. Unused, open channels (having no defined signal) should not be configured with sensitive input ranges since otherwise the measurement data could be affected. Configure unused channels with a broad input range or short them out. The same applies to channels not configured as active.
4. To measure voltages >60 V use adequate plug.
5. In case you are using a removable storage medium, please be aware that before you remove it (if the device is switched on), the button (1) must be pressed to ensure that storage medium can be safely removed. Please read the instructions in the chapter "removable storage".
6. Avoid prolonged exposure of the device to sunlight.
7. Be certain that the ventilation slits remain unobstructed.
8. Note that parts that are not explicitly intended to be carried may be warmer than the handles. The use of handles is mandatory for safe use. In the event of deviations, other suitable methods must be used to ensure acceptable protection against burns. Under normal conditions, the surface temperature of the enclosure/housing does not exceed the limits for accidental contact according to IEC 61010-1. The handles also prevent the lateral plug contacts from being touched during a measurement, thus preventing accidental discharge (ESD) into the lateral plug contacts. ESD in the lateral plug contacts can lead to a crash of a running measurement (destruction does not take place).

3.4 Attachment mechanism

Stacking of the imc CRONOSflex Modules

1. Hook tongue into the groove

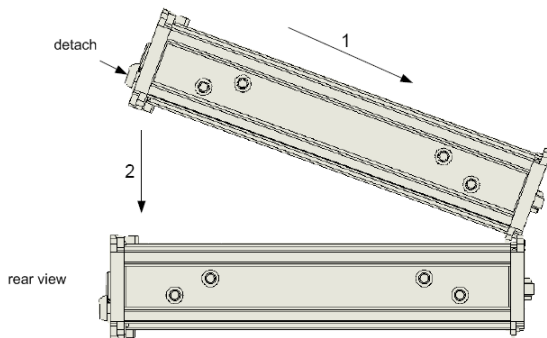

2. Press modules together

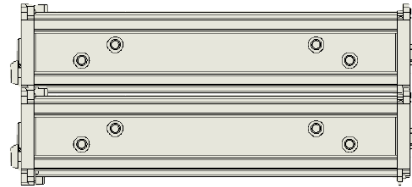

You will here a "clicking" sound after successfully connecting the modules.

After successfully clicking the modules together, you should hear a "click sound".

The modules are now mechanically locked and electrically connected!

Detaching modules from the stack

1. Detaching

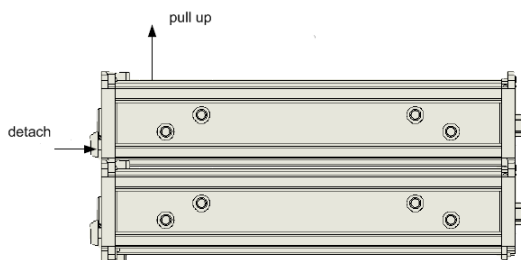

2. Pull tongue out of groove

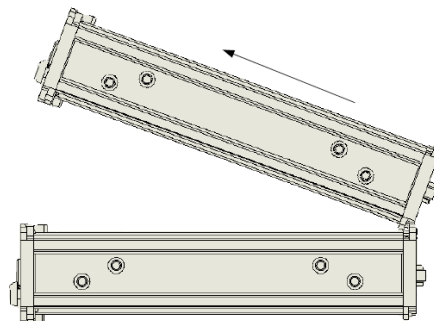

Note

Handling

- Be aware that **during a running measurement**, modules should not be disconnected from the system (hot plug functionality is not supported during a running measurement).
- To avoid damage: Before clicking together or removing modules and power handles, disconnect the supply lines and switch the system off, in order to ensure that the system is disconnected from the supply voltage.
- The **CRFX handles** are mandatory for the safe transport and handling of a module block: e.g. CRFX/HANDLE-L (left, 11900008) and CRFX/HANDLE-R (right, 11900007).
- A **maximum total length** of 85 cm of attached (clicked) modules should not be passed! Mounting elements *can* be used for more stability.
- The sizes (drawings) of all available modules are listed in a separate document (data sheet). The dimensions, the distances of the bore holes for available mounting elements are also stated in this separate document.



[Description of the mounting systems](#)

3.5 Signal connection

For devices with DSUB-15 connection technology, the convenient imc terminal plugs for solderless screw terminal connection are available as optional accessories.



ACC/DSUBM-xxx: snap the nose into the slot

Open the Metal plug:

1. Unscrew the cable fitting (cable gland) [A]
2. Remove the bend protection [B]
3. Unscrew the lid screws [D]
4. Lift the lid in the DSUB connection area and unfasten the nose of the slot

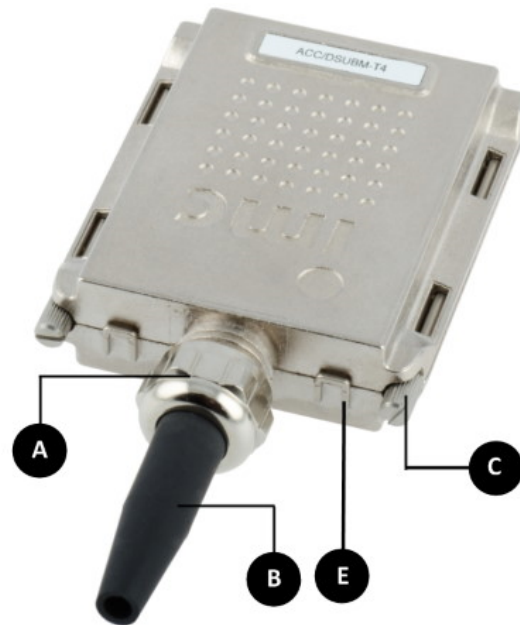
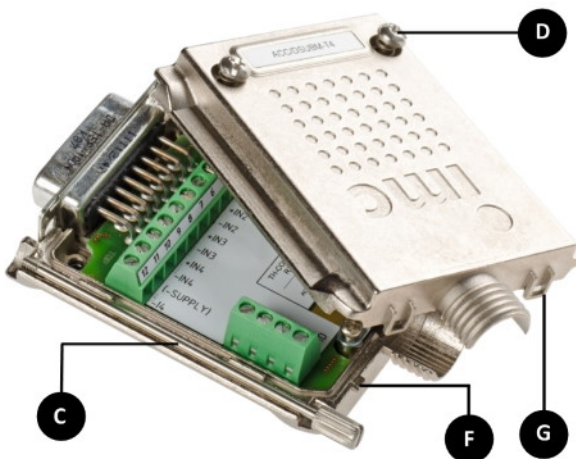

- A: Cable fitting (cable gland)
- B: Bend protection
- C: Fastening screw for the devices' front panel
- D: Lid screws
- E: Locking key (Nose / Slot)
- G: Slot
- F: Nose

Close the Metal connector:

1. Assemble the lid by snapping the nose into the slot (see the picture above)
2. Audible click when the lid snaps in the front of the DSUB pod
3. Insert the bend protection
4. The pressure nut must be screwed back on
5. The lid screws can be tightened

 [Reference](#)

[Pin configuration](#)

Please find the pin configuration of each available plug in the chapter: [Pin configuration](#) ⁵⁷.

3.6 imc CRONOSflex Description of the system

3.6.1 Building Block Principle Maximizes Flexibility

The inherently modular construction of imc CRONOSflex eliminates the constraints of a predefined [system size or configuration](#)^[38], found in usual data acquisition systems. Integrated modules free the user to design – and redesign – their system as required: small and compact one day; a large number of channels, of different sensor types with tailored signal conditioning the next. Today a centralized bench top system; tomorrow a decentralized system with satellite modules each assigned to a remote measurement site. The flexibility of imc CRONOSflex allows the reuse of system components to build the optimal solution in a matter of seconds; the system's scalable and expandable architecture eliminates the need for exact planning when purchasing equipment for a specific application. Based on EtherCAT, the [system bus](#)^[18] to connect the central base unit with measurement modules, it is possible to both connect the measurement modules directly to a central unit, and/or to set up a spatially distributed system by means of standard Ethernet network cables (RJ45, CAT5). The resulting measurement system can be managed from a PC (also connected via an Ethernet LAN or WLAN) which serves as the configuration tool and repository for measured data.

However, the system can also work autonomously without a control PC: either starting immediately upon being powered, or automatically at a specified time according to a pre-set autostart configuration. In either case, the recorded data may be saved to the device's storage (hard drive, flash card or USB media), or to a network drive. Data can be retrieved from a remote device directly (removable storage media), or via the network if there is a (temporary) outside connection.

3.6.2 System bus

The selection of EtherCAT as the system bus provides the user with the advantage of being able to set up a distributed measurement system with standard CAT 5 network cables, including those in an existing Ethernet infrastructure. EtherCAT's software protocol is an established industry standard which supports deterministic transfers and synchronization mechanisms, guaranteeing precisely synchronized measurements throughout the network.

3.6.3 Modular components "click" together

The individual modules are constructed to form a tight mechanical connection "with a click", while being electrically connected to the imc CRONOSflex data bus and, if desired, power. When added or removed, hardware modules are also automatically included/excluded by the imc STUDIO software. An optional powered handle unit can be attached to the stack in the same manner as imc CRONOSflex Modules, optionally containing a stabilized 50 V system power supply unit with buffered uninterruptible power supply (UPS). When ["clicking together \(connecting the components\)"](#)^[18] modules in this way, you create a portable, centralized measurement system which can subsequently be customized both in terms of the module types and quantity.

3.6.4 Distributed measurement system

For even more flexibility, the EtherCAT based imc CRONOSflex system can be physically distributed using standard cables (RJ45, CAT5). Additional measurement modules can be connected, individually and as local blocks of modules which are locally clicked together, but remote from the base unit. The combination of these two connection techniques, centralized "clicked" stacks and distributed cable connected modules and substacks, allows any imaginable topology of measurement locations to be joined together into a logically integrated, centrally controlled, data acquisition and control system.

3.6.4.1 System structure and components

A complete system always consists of a central imc CRONOSflex base unit and a flexible amount of imc CRONOSflex modules (AMP). The imc CRONOSflex base unit is available as a variety of models. With either one or two fieldbus interfaces (each with two nodes), as well as an optional Multi-IO extension, which provides digital inputs and outputs plus incremental counter measurement channels and analog outputs.

imc CRONOSflex as a decentralized, distributed measurement system

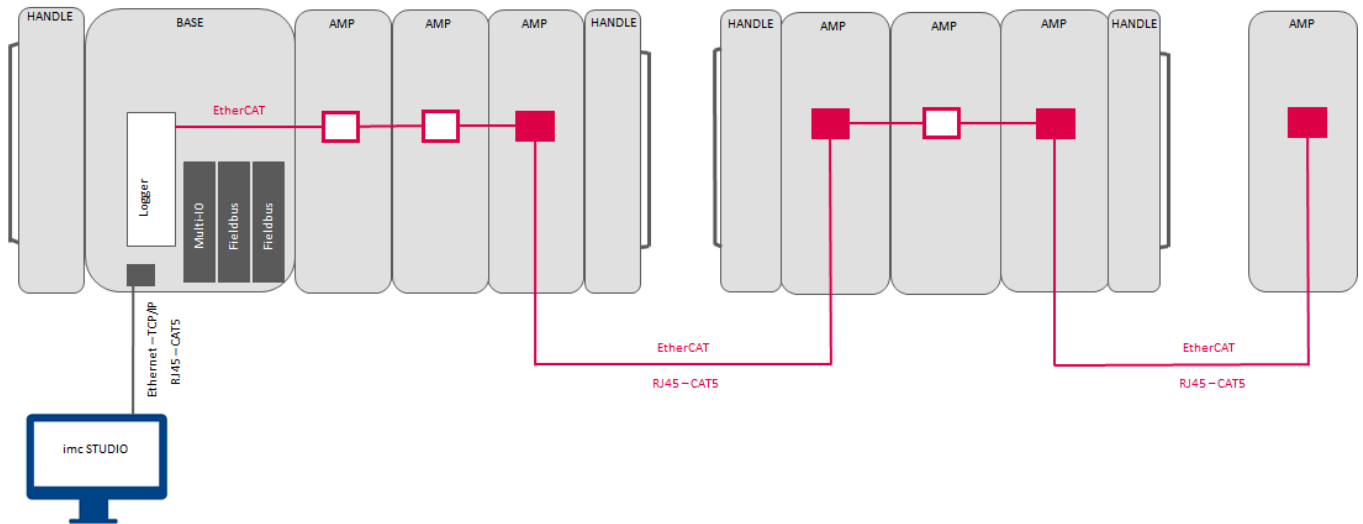

3.7 Networking and power supply

All of the system's individual building blocks, both the imc CRONOSflex base unit and also each individual imc CRONOSflex measurement module, have their own LEMO sockets for an ultra-wide 10 to 50 V range of DC power input; additionally, each have two RJ45 network jacks (IN/OUT) for connecting the EtherCAT system bus. Both lines have robust connection terminals which provide both [mechanical attachment to modules \(locking snap\)](#)^[16] and electrical connection without any additional cables. By this means, multiple directly attached modules can be jointly powered by a single DC source which is always connected [at the "far left" or "first" module](#)^[35]. If multiple power sources are accidentally connected to the same block of modules, then a latch circuit ensures that only the first module on the left receives the power.

With the **introduction of the 48 VDC power adaptor** for the imc CRONOSflex system (CRFX base unit and the CRFX input modules), the power supply socket on the device has been changed so that the 48 VDC power adaptor can only be used with imc CRONOSflex systems and not with other imc measurement devices with an input supply voltage of 10..32 VDC. You can identify the 48 VDC power adaptor at the **blue protective sleeve** at the LEMO.1B plug (LEMO.PHG.1B.302), see [the following Fig.](#)^[20] The 15 VDC or the 24 VDC power adaptors are equipped with a **black protective sleeve** at the LEMO.1B plug and can also be used with imc CRONOSflex systems. The use of those power adaptors with imc CRONOSflex is not recommended. The imc CRONOSflex system have an input supply voltage range of 10 .. 50 VDC. The DC-supply inputs of our imc measurement devices are not designed for a connection to a DC-grid.

! Note

The +pin is marked with a red dot!



input power supply socket LEMO.1B (female)
for a connection with 24 VDC power adaptor
(1 guide notch, LEMO.EGG.1B.302)

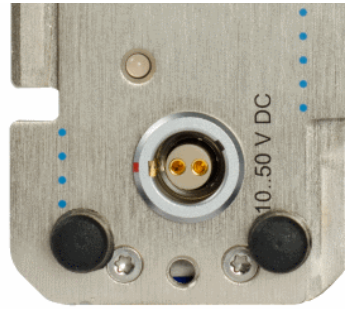

input power supply socket LEMO.1B (female)
for a connection with 48 VDC power adaptor
(2 guide notches, LEMO.EGE.1B.302)

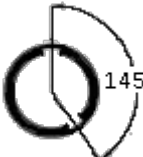
			plug-type (female):	
			<i>LEMO.EGG.1B</i>	<i>LEMO.EGE.1B</i>
			1 coding notch	2 coding notches
			up to 8/2011	as of 9/2011
plug-type (male):		power adaptor:		
<i>LEMO.FGG.1B</i>	1 coding key	15 V, 24 V	fit	fit
<i>LEMO.FGE.1B</i>	2 coding keys	48 V	fits only with ACC/FGG-ADAP-PHE	fit

If the imc CRONOSflex base unit runs with 48 VDC power supply rather than the 24 VDC power supply, it is possible to operate a larger number of modules or a module with more power consumption directly with one power adaptor. The power consumption of the modules can be as high as 149 W with a 48 VDC power supply. If you want to benefit of the [Power over EtherCAT \(PoEC\) function](#) ⁴³ a minimum voltage of 42 VDC is necessary.

For all previously delivered imc CRONOSflex systems with the LEMO.EGG.1B power supply socket (with one guide keyway), to be powered in future with 48 VDC, use the adaptor cable "CRFX adaptor cable for the supply LEMO.1B (article number: 13500151, order code: ACC/FGG-ADAP-PHE)" and the 48 VDC power adaptor.



Note

This adaptor cable may only be used with imc CRONOSflex. For devices with the 10..32 VDC input voltage range (imc C-SERIES, imc SPARTAN, ...), use of this adaptor cable and the 48 VDC power unit can damage or destroy the devices.



power adaptor 48 V up to 150 W (with blue protective sleeve at the plug) article no. 13500148

All imc CRONOSflex base units and Input Modules having the changed power supply plug can be continued to be powered with the 24 VDC power adaptor (without adaptor cable).

3.8 Main switch

The imc CRONOSflex base unit has a central main switch by which the complete block of directly clicked (stacked) modules is activated/deactivated. Independently powered, spatially distributed modules and [subsystems \(blocks\)](#) are activated/deactivated directly via their power supply connections.

3.8.1 Remote control of the main switch

As an alternative to the manual main switch on the device's front panel, a remote-controllable electric contact can be used to switch the device on and off. The socket designated "**REMOTE**" provides this contact: connecting the signals "SWITCH" and "ON" switches the device on, connecting "SWITCH" to "OFF" switches the device off. Any switch or relay contact used for this purpose must be able to bear a current of approx. 50 mA at 10 Ω max. The reference voltage for these signals is the primary voltage supply.

The signal "**SWITCH1**" serves to run the device with the switch permanently bridged: when "ON" and "SWITCH1" are connected, the device starts as soon as an **external supply voltage** is provided.

If this supply is interrupted, an internal buffer keeps the **base unit** activated for the appropriate buffer duration in order to close the measurement and files, and then the device deactivates itself. This type of operation is specially designed for use in a vehicle, permanently couples to the ignition and not requiring manual control. Pinout: LEMO.1B.306 socket

Short description of the signal:

Signal	Function	Connection	Remarks
SWITCH	switch signal / reference	connect to ON / OFF	Power up from internal battery is supported!
SWITCH1	activation only from external power supply	connect to ON / OFF	static, permanently jumpered: for automatic activation upon application of an external supply

3.9 Power over EtherCAT (PoEC)

imc CRONOSflex Modules are compatible with Power over EtherCAT (PoEC), meaning they can receive power completely from the EtherCAT connection cable and consequently no longer need their own power supply line. This is especially attractive for decentralized satellite modules positioned somewhere remote and inaccessible, and having no other outside line than the CAT5 cable. Thus, centrally remote-controlled activation/deactivation of these satellites is achievable by means of PoEC.

3.10 Storage media in the device

This section describes how to handle the storage media of the imc measurement devices and how to use them with imc STUDIO.

The storage media are exclusively for data acquisition with imc STUDIO.

Storage media with verified performance can be purchased as accessories from imc. Hard drives are ordered with the device and can only be installed subsequently by imc.

**Note****Manufacturer and Age of the storage medium**

- imc has no way to affect the quality of the removable storage media provided by the various manufacturers.
- Storage media which come with newly purchased devices have been inspected in the framework of quality assurance and have passed the relevant tests.
- We expressly declare that the use of removable storage media is at the user's own risk.
- imc and its resellers are only liable within the framework of the guarantee and only to the extent of providing a substitute.
- imc expressly declines any liability for any damages resulting from loss of data.

3.10.1 For devices of the firmware group A (imc DEVICES)

Swapping the storage medium

Pressing the button signalizes to the system that you intend to remove the storage medium. Once this is done, the device stops access to the storage medium. If you were to remove the drive without prior announcement, it could produce defective clusters. If the storage medium is removed while a measurement is in progress, the data records are not completed. Therefore, always proceed as follows when swapping the storage medium:

1. **Important!** Before removing the storage medium from the measurement device, first announce the procedure to the system by pushing the button, in order to **avoid damage** to the storage medium.
2. Once the LED blinks, remove the storage medium.
3. Insert the new storage medium. Devices indicate by a short flash that the new drive has been successfully recognized.

Hot-Plug (exchanging the storage medium during a measurement)

It's possible to exchange the storage medium during a running measurement. This makes it possible to carry out a measurement without a PC practically without any limitations. It is only necessary to check the amount of memory available using imc Online FAMOS. To do this, use the function `DiskFreeSpace` belonging to the group "System". You can set an LED, for instance, or a digital output or a beeper to be activated when less than the minimum amount remains. One convenient solution would be to have a readout of the remaining space outputted by a display variable, which would indicate by a display on the device how the remaining memory decreases.

While swapping the storage medium during a running measurement, the data are stored in the measurement device's internal memory. If you complete the process within the specified RAM buffer duration, this is certain to work without any loss of data (see section "*RAM buffer time*"). Note that not only the time for the swap must be buffered, but that the buffered data must also be transferred to the new disk once the swap has been completed.

Swapping the storage medium

1. **Important!** Before removing the storage medium from the measurement device, first announce the procedure to the system by pushing the button, in order to **avoid data loss and damage** to the storage medium. The LED will **shine continuously** in green.
2. Once the device is ready for removal of the storage medium, the LED **blinks**.
3. Remove the already full storage medium.
4. No announcement is necessary for inserting a storage medium.

3.10.1.1 Storage media

Storage media	Description
CF Cards (Compact Flash)	<p>For devices of group A4 and A5:</p> <p>The device group exclusively uses CF cards for storage medium.</p>
USB Storage Medium	<p>Concerning devices with USB (see "<i>Device overview</i>"). Memory sticks or external hard drives can be connected at this terminal.</p> <ul style="list-style-type: none"> • Do not use multiple storage media at the same time! Devices belonging to group A6 have two USB terminals and a slot for the ExpressCard. However, the device can use only one data storage medium. The system determines which one it is upon activation, and there is no fixed order of precedence among the media. For this reason, delete any which you do not wish to use for the measurement before switching the device on. • With USB, the Hot-Plug ^[22] functionality is available. Make sure that sufficient time is available for swapping the storage medium. How much time is required for de-registering and re-registering with the system depends on the particular storage medium and on the number of channels. As an orientation value, we recommend at least 30 s, even for simple configurations! <div style="border: 1px solid orange; padding: 5px; margin-top: 10px;"> <p>Do not use USB hard drives with external power supply</p> <p> Please do not use any USB hard drive which has an external power supply. Such a drive may not be connected at the imc USB-port. Otherwise, when the measurement device is powered down, the imc USB-port's current limiting mechanism may be destroyed.</p> </div>
ExpressCard	<p>Applicable to devices having ExpressCard slot (see "<i>Device overview</i>").</p> <ul style="list-style-type: none"> • Remove any connected USB storage medium! Devices belonging to group A6 have two USB terminals and a slot for the ExpressCard. However, the device can use only one data storage medium. The system determines which one it is upon activation, and there is no fixed order of precedence among the media. For this reason, delete any which you do not wish to use for the measurement before switching the device on. • With ExpressCards, the Hot-Plug ^[22] functionality is available.
CFAST	<p>Concerning devices with CFAST slot (see "<i>Device overview</i>").</p> <ul style="list-style-type: none"> • Remove a connected USB storage medium! The device can use only one data storage medium. The system determines which one it is upon activation, and there is no fixed order of precedence among the media. For this reason, delete any which you do not wish to use for the measurement before switching the device on. • With CFAST cards, the Hotplug ^[22] functionality is available.
SSD	<p>Applicable to devices having a hard drive (see "<i>Device overview</i>").</p> <ul style="list-style-type: none"> • With SSD hard drives, Hot-Plug ^[22] is not possible! If the SSD is used in a frame for removable data carrier, it can be exchanged while the device is deactivated. • SSD hard drives appear in the device software as a hard drive and can be read out via the Explorer-shell ^[24]. • Due to the formatting, the content of the SSD in the PC is not displayed when the SSD is connected directly in the PC. SSD hard drives can only be formatted in the device ^[27]. • In addition to the SSD, a CF/CFAST-card can be inserted in the measurement device and used alternatively.

3.10.1.2 Data transfer

The internal storage medium can be accessed **directly via Windows Explorer**. Alternatively, the storage medium can be inserted into a **card reader** on the PC (suitable for large amounts of data due to faster transfer).

Warning

- Do **not use force** to insert or remove the device storage medium.
- During a **running measurement** having a high sampling rate, you should **never** try to **access the storage medium in the device** using the Windows Explorer shell. Otherwise, this additional burden could cause a data overflow.

Note

A tip on **interval saving**: Supposing the system's power supply suffers an outage during a measurement, it would not be possible to guarantee that the data file on the storage medium is terminated properly. This may lead to a failure to record the last measurement taken. Saving at intervals is a way to reduce this risk.

Access via Windows Explorer

The menu item "*Data (Device)*" (📁) causes the Windows-Explorer to start while indicating the device selected.

Ribbon	View
Extra > Data (Device) (📁)	Complete
Home > Data (Device) (📁)	Standard

Access via "*imc Systems*" - an Explorer shell extension

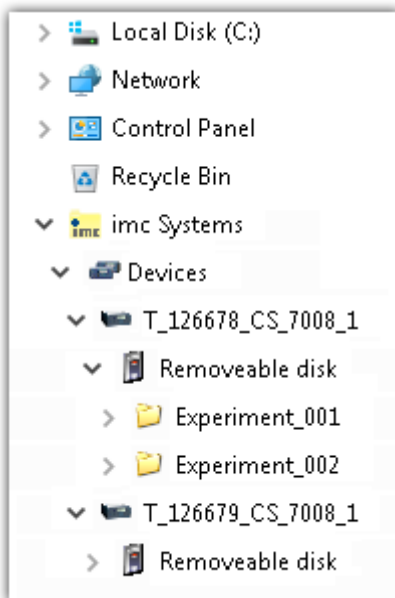

While installing the operating software, if the option "*Extension for Windows-Explorer*" is activated, you are able to copy, display or delete the files of measured data saved within the device (e.g. on the removable storage medium). The method of doing this is the familiar one under Windows.

This function is independent of the device software. As well, selection of the devices in the tree diagram is independent of the device list in the operating software.

In order to get access to your device's storage medium, you must first add it to the tree diagram (see "[imc Systems - Adding a device](#)"^[25]). Subsequently, you are able to navigate to the desired data in the storage medium and thus to work with them.

3.10.1.2.1 imc Systems - Adding a device (Add)

Even if you have already been connected with the device by means of the imc STUDIO software, it is still not listed in the Explorer. It's possible to measure with one device while copying data from another.

- Click on "Devices" under "imc Systems" to highlight that entry.
- Open the context menu over the "Devices"-area and select "Add".

The "Add device interface" dialog appears:

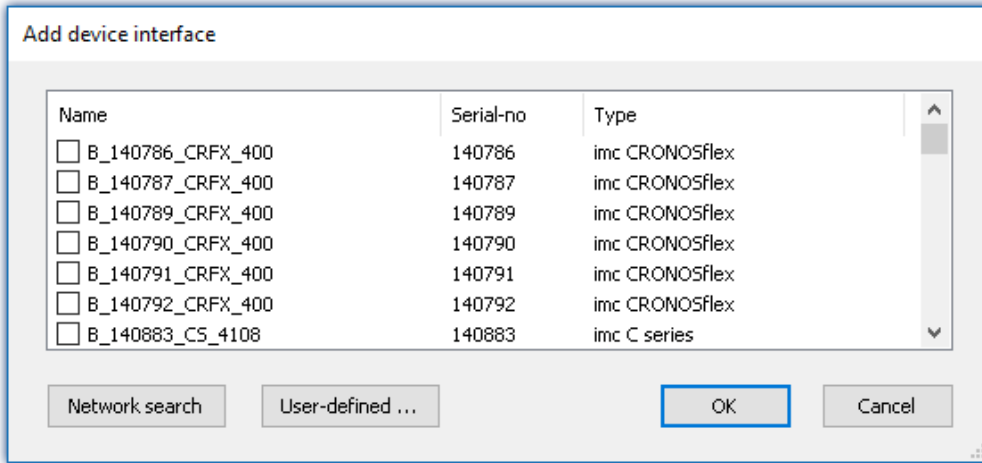

Add Device interface

Search for devices	Description
Network search	<p>"Network search" causes the system to search the network for any suitable devices. How long this will take depends on how many devices are connected and on the network type. Ultimately, the devices found are listed.</p> <p>Select your measurement device and confirm your selection with "OK". The measurement device is then available.</p>
User-defined	<p>In a structured network (network with routers, Internet, ...), imc devices could not be integrated by means of a network search. With the knowledge of the IP address or of the domain name (DNS name), it is now possible to integrate a device into the list.</p>

Reference

More information is presented in the section: "Setting Up - Connect the device"

- General: "Device connection via LAN"
- "Connection via a direct address"

3.10.1.2.2 FTP access

It is also possible to access the device's internal data via FTP, as well as to transfer data. Other goals are to change the configuration of devices via FTP and to restart the device for measurement with the altered configuration. Application areas include test drives, where there is no way to connect the devices directly with the device software. The Diskstart/Autostart capabilities are applied and enhanced. For this purpose, the device is usually configured for autostart. Upon activation, the configuration is loaded and the measurement, as well as data transmission, starts automatically.

Start the explorer and enter "`ftp://`" and the IP address of the device:

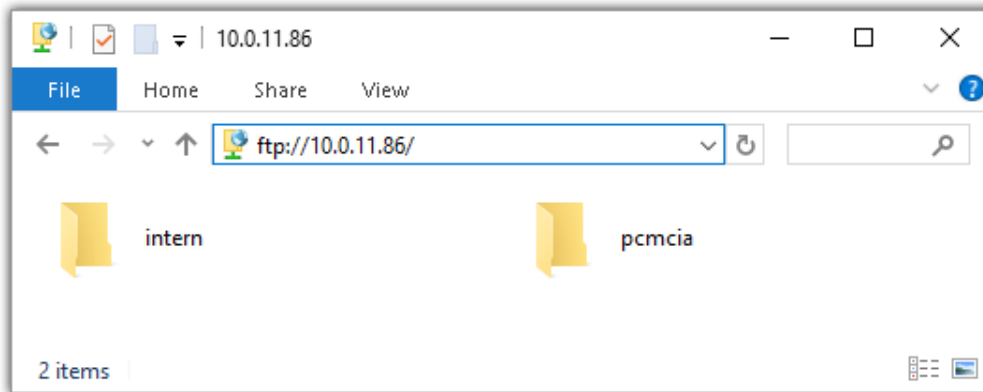

Note

- In general it is a read only operation. If you intend to delete files via FTP, you have to add "`imc@`" between "`ftp://`" and the IP address:
Example: <ftp://imc@10.0.10.219>
- Furthermore, a password can be assigned to protect access via FTP. This password is entered into the device properties.

Warning

The following limitations apply when accessing the storage media in a device via an FTP-client:

- The device can't delete folders, accessed by a FTP-client.
- It is not possible to replace the storage medium during measurement (Hot-Plug).

3.10.1.3 File system and formatting

Storage media with the file systems FAT32 and FAT16 (maximum 2 GB) are supported. It is recommended that a memory card be [formatted](#)^[27] and possibly partitioned before use.

**Note**

Routine formatting protects the memory card

Routine formatting is recommended

Take every opportunity to format the storage medium. **Recommendation:** at least every **six months**.

In this way, any **damaged storage medium** can be detected and repaired if possible. A damaged file system may cause **data loss**. Or the **measurement system may fail to start** correctly.

In order to avoid data loss, any data still needed should first be saved!

Using a data storage medium in different devices

There are no known limitations. But it is recommended to always format the medium whenever transferring it in order to avoid data loss.

Additional notes

- To select the appropriate file system for the respective application, observe the notes on the data rate and on "[Avoidance of Data Overflow](#)"^[27].
- No limitations regarding the currently available storage medium volumes are known.
- The maximum filesize is 2 GB. In case a signal would exceed that limit, use interval saving.

**Notes**

General restrictions applicable to file systems

Please observe the general restrictions regarding the respective file systems.

3.10.1.3.1 Formatting

The formatting can be performed directly in the PC's hard drive by the Windows operating system, or in the device using the Explorer shell.

**Note**

Recommendation

- **imc recommends formatting in the device:** In comparison to formatting by Windows, this provides higher data writing rates for high-speed channels.
- Only **one(!)** partition may be created. Multiple partitions may cause the measuring device not to recognize the storage medium.

**Warning**

Please back up the data first

Formatting causes all data on the storage medium to be deleted. Before performing the formatting, ensure that all data have been saved on a different storage medium.

 Note

Cluster size - Avoidance of Data Overflow

The size and number of assignment units (clusters) and thus also the [file system](#)^[27] used have a substantial effect on the storage medium's speed! Small clusters can dramatically reduce the speed! If high data rates are required, it is normally recommended to have a size of 8 kB/cluster.

The optimum size of the clusters must be determined for each storage medium separately. For all of them, the following applies:

- **Few channels having a high data rate**

If a few channels having a high data rate are being recorded, then **large clusters** on the data carrier provide better advantage. Formatting with FAT32 on the PC and drive sizes < 8 GB creates disadvantageously small clusters, which in conjunction with the full aggregate sampling rate can lead to a data overflow.

Whenever using cards of up to 8 GB, always use the formatting by the device.

In the device, cards larger than 512 MB are formatted with 8 kByte clusters and cards larger than 4 GB are formatted with 16 kByte clusters. Cards of up to 1 GB can alternatively be formatted by the PC with FAT16. With cards of 16 GB onward, there is no difference whether the formatting is done in the PC or in the device.

- **Very many channels with a low data rate**

If hundreds of channels having a low data rate (e.g. CAN channels) are saved, the exact opposite is true. Here, **small clusters** are an advantage. This means that drives with up to 8 GB should in such cases be formatted in the PC with FAT32.

Formatting in the device (Recommended)

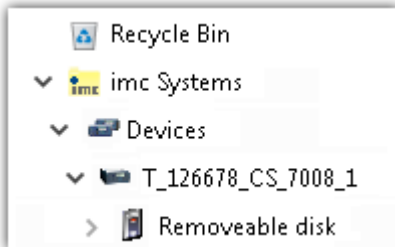

For **formatting in the device**, navigate via the Explorer shell "[imc Systems](#)"^[24] to the desired device.

There, open the properties of the drive: context menu > "*Properties*" (not via the Navigation pane in the Explorer).

Go to the Property dialog under the tab: "*Tools*".

Start the formatting by clicking on "*Format now!*".

The device performs the formatting according to the following rule:

Drive size	Cluster size	File system
<= 512 MB	2 kB	FAT16
<= 4 GB	8 kB	FAT32
> 4 GB	16 kB	FAT32

 Note

Formatting the storage medium is not allowed if an experiment whose data are to be saved internally has just been prepared.

Formatting using the Windows-Explorer

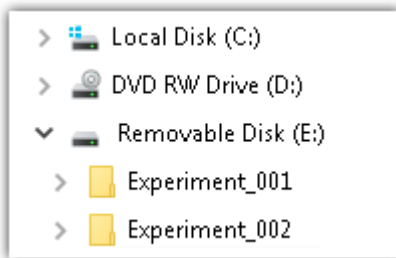

To perform **formatting of a storage medium via the [Windows-Explorer](#)**²⁶, navigate to the desired storage medium. Run the formatting by means of the context menu, for example.

Select one of the following two file systems: "FAT32" or "FAT" ("FAT16").

The file system "FAT32" is designed for media **larger** than 32 MB. Under no circumstances can smaller media can be formatted to "FAT32". With "FAT32", Windows generates 4 kByte clusters when the drive size is up to 8 GB, which is inconvenient for high-speed writing rates.

SSD hard drives are inherently formatted with Ext2 and for that reason **can not be formatted directly in the PC**, but only in the [device](#)²⁷.

However the Ext2 format offers these advantages:

- Mistaken duplicate occupation of individual clusters is not possible.
- Integration into the operating system is accomplished much more quickly than with FAT32.
- Higher writing output than with FAT32.

3.10.1.4 Known issues and limitations

Known issues and limitations	Description
If the memory card can not be read under Windows	The memory cards must first be partitioned (formatted) under Windows. Windows automatically generates the correct partitioning information. Subsequently, the memory card should be formatted again in the device. When in doubt, please contact our tech support ^[6] .
The system won't recognize the data storage drive	<ul style="list-style-type: none"> • Answer 1: Check the file system: The device supports FAT32/FAT16 ^[27]. • Answer 2: If there are two storage media simultaneously plugged into your device, only one media will be detected (e.g. USB and CFast). Only the first plugged media will be detected.
File system becoming gradually slower	As the count of folders increases, so does the time required by the system to access the data. In consequence, the data saving procedure becomes slower and data loss becomes possible. For this reason, creating more than 1000 folders is to be avoided.
Errors in accessing the storage medium	<p>Errors can have the following causes, among others:</p> <ul style="list-style-type: none"> • The data rate is too high, the storage medium can't keep up and data overflow results. • The storage medium is full. <p>The device signals any error by flashing this LED. Its further responses depend on whether or not the device is connected to the PC.</p> <ul style="list-style-type: none"> • If no PC is connected, for instance in cases involving automatic self-start capability, the button lights continuously. At the end of an experiment, always check for this if measurements are taken without PC aid. • If the PC is connected to the measuring device, imc STUDIO documents the error with an message in the Logbook and switches the LED off. Any one-time data overflow only shows up in the Logbook, since the LED is reset afterwards. If data overflow occurs repeatedly, The LED is activated again, the PC records the message again, and as a result the LED blinks intermittently.
Data overflow due to improper cluster size	<ul style="list-style-type: none"> • With a storage medium formatted by Windows to FAT32 ^[27], data overflow can occur if a high aggregate sampling rate is generated by a few high-speed channels. • With a storage medium formatted in the device ^[27], data overflow can occur if a high aggregate sampling rate is generated by very many low-speed channels.

3.11 Saving data in case of power outage

In case of an outage or interruption of the system's DC power supply, an internal buffer battery in the base unit ensures that any running measurement is ended in a controlled manner, that all measured data are safely transferred to the internal data storage and that the associated files are correctly closed. This procedure can take up to several seconds. Subsequently, the system shuts down automatically.

The standard-equipped system's internal supply buffering extends to the base unit, not the imc CRONOSflex Modules which are either directly stacked or connected by cable, and is provided for the purpose of preserving the data integrity under any conceivable operating circumstances.

Additional buffering for the entire system, including the imc CRONOSflex Modules, so as to ensure uninterrupted measurement operation even during phases of power failure, is also possible in conjunction with the optional UPS supply module which comes with the carrying handle. This makes mobile battery operation possible, or even bridge over power during vehicle starting processes. With UPS operation of this type, it is possible to set a so-called "buffer time": this time period specifies after how long a continuing power outage is no longer to be backed up, and thus when closure of the measurement and automatic deactivation are to be initiated.

3.12 Stabilized device supply and UPS (Power Handle)

Comprehensive systems with correspondingly high performance requirements can, in conjunction with low supply voltage and thus a high resulting current (e.g. 12 V in a vehicle), exceed the amperage capacity of the module terminal connections (max. 3.1 A). For this reason the possibility is provided to equip the left carrying handle with an optional supply unit, which generates a constant high system supply voltage of 50 V at max. 100 W from the 10 V to 50 V wide range supply voltage.



Power Handle

This not only makes it possible to reliably supply very large systems, but also to use the measurement modules' PoEC capabilities across the entire wide voltage supply range: according to PoEC specs, for PoEC functionality a minimum supply voltage of 42 V on the network line is required. This is provided by the supply unit in the handle for the entire 10 V to 50 V range. The [optional handle](#) ³⁹ can additionally be equipped with a UPS function to ensure the device's operation even during a power outage. UPS units are available with a choice of either lead or Li-ion batteries.

3.12.1 Li-Ion batteries

The Li-ion batteries (Smart Batteries) are accessible for exchange, with a keyed insertion mechanism, secured against reversed polarity. With imc CRONOSflex (CRFX) the Li-ion batteries are accessible on the rear side of a handle: CRFX/HANDLE-LI-IO-L.

Note

- Due to the inevitable leakage and self-discharge of the Smart Batteries we recommend a regular recharging cycle at least every 3 months that a device has not been in use (device must be switched on for charging).



Li-ION

Do not deposit Li-ion batteries in domestic recycling containers!

Reference

Li-ion battery

Please find the technical specs of the Li-Ion battery in the manual.

Notes on Li-ion Smart Batteries:



- Failing to adhere to the recommended temperature ranges for storing, charging and discharging will not render the battery pack unsafe but will reduce its life expectancy and capacity.
- If Smart Batteries are stored in low charge state (<10%) they will age faster.
- When storing discharged Smart Batteries, internal deep discharge protection circuitry may get activated. This will cause the following charge cycle to run through a reactivation procedure, starting with a very low charging current. This may prolong the required charging time.
- Prolonged storage of discharged batteries is not recommended and may cause irreversible damage to the battery!
- The battery may temporarily deactivate itself in response to:
 - excessive temperature
 - excessive discharge current (e.g. due to short circuit)
 - insufficient cell voltage (to prevent discharge)
 Otherwise the UPS is operable as long as the battery does not prevent discharge.
- Once the passive temperature fuse has been triggered, it cannot be reset and thus renders the battery pack unusable. The rated temperature may not be exceeded!
- For safety reasons, the Li-ion batteries may not be exposed to temperatures exceeding 100°C!

 **Note**

In order to preserve maximum life expectancy of the Smart Batteries they should be recharged at least every 3 months. The device must be switched on for charging!

State of charge indicator of the Li-ion batteries

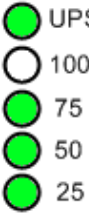
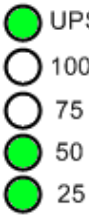
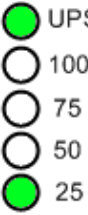
The state of charge of the Li-ion batteries is indicated by different signal patterns of the LEDs. The position of the LEDs on your measurement device can differ from the pictures below. The following signal patterns can be interpreted as follows:

 <p>UPS Status</p> <p>100</p> <p>75</p> <p>50</p> <p>25</p> <p>state of charge:</p> <p>75% to 100%</p>	 <p>UPS Status</p> <p>100</p> <p>75</p> <p>50</p> <p>25</p> <p>50% to 74%</p>	 <p>UPS Status</p> <p>100</p> <p>75</p> <p>50</p> <p>25</p> <p>25% to 49%</p>	 <p>UPS Status</p> <p>100</p> <p>75</p> <p>50</p> <p>25</p> <p>10% to 24%</p>	 <p>UPS Status</p> <p>100</p> <p>75</p> <p>50</p> <p>25</p> <p>Flashing at 2 Hz</p> <p><10%</p>
---	--	--	---	---















During active charging the last active one of the four green status LEDs flashes at a rate of approx one second. In contrast to this, the warning signal at very low state of charge (<10%) consists in the lowermost ("25") flashing at an even faster rate.

The UPS Status LED is bicolor. In case of an error it flashes red.

Error Conditions

If the UPS Status LED flashes alternating red and green, a long term continuous battery operation is inhibited due to high battery temperature of $60^{\circ}\text{C} \leq \vartheta < 75 \pm 5^{\circ}\text{C}$ (1). In this case, the buffer time constant of the UPS is reduced to 15 seconds, regardless of the configured setting. Thus, in case of an outage of the external power supply automatic shutdown procedure will already be initiated after 15 seconds, stopping the current measurement, storing all data and turning off the device.

The following error conditions are indicated by LED signal patterns:

<p>Battery is not present or cannot be detected</p> <p> UPS Status</p> <p> 100</p> <p> 75</p> <p> 50</p> <p> 25</p>	<p>Internal Error (UPS may not be operable)</p> <p> UPS Status</p> <p> 100</p> <p> 75</p> <p> 50</p> <p> 25</p>	<p>Battery operation is inhibited and the UPS is not operable $\vartheta \geq 75 \pm 5^{\circ}\text{C}$ (2)</p> <p> UPS Status</p> <p> 100</p> <p> 75</p> <p> 50</p> <p> 25</p>
--	--	---

(1) $\pm 5^{\circ}\text{C}$ due to tolerances of internal temperature measurement of the battery

(2) Internal protection circuitry prevents discharge at temperatures above $\vartheta \geq 75 \pm 5^{\circ}\text{C}$. The UPS may only be operable again once the batteries have cooled down to 65°C .

3.13 Isolation and grounding concept

3.13.1 Isolation

The imc CRONOSflex Modules' supply inputs are each isolated from the frame (CHASSIS) and measurement electronics. This ensures in particular that in spatially distributed systems, where no common CHASSIS or ground voltage for all subsystems can be assumed, neither uncontrolled ground loops nor compensation currents occur. Neither the base unit's supply input, nor the voltage it supplies to the measurement modules, is isolated. In a distributed system, therefore, the base-system's housing (CHASSIS), and the directly connected amplifiers, as well as their supply voltage level are to be seen as the central reference voltage (neutral point), to which the distributed satellites and their respective frames and supply voltages may each have a voltage differential. For the purpose of controlled grounding, each of the imc CRONOSflex Modules has a dedicated grounding contact on the lower part of its front panel.

Since the various housing frames and their reference grounds have a connection to the network cables via the shielding, it may be necessary to use network cables whose shielding has contact on only one side. In especially demanding applications, such as installation on board rail vehicles, where high static as well as dynamic ground differentials can exist across the various wagons, it is also possible to use fiber optic network converters for a pure optic EtherCAT system bus connection. Appropriate mechanically integrated converter modules for CRONOSflex are in preparation.

Concerning the isolation of imc CRONOSflex Measurement Modules' electronics from their respective frames, there are different options: modules both with isolated measurement inputs (e.g. ISO2-8) and without isolated measurement inputs (e.g. UNI2-8) are available.

3.13.2 Grounding concept

Isolated power inputs avoids ground loops in distributed topologies

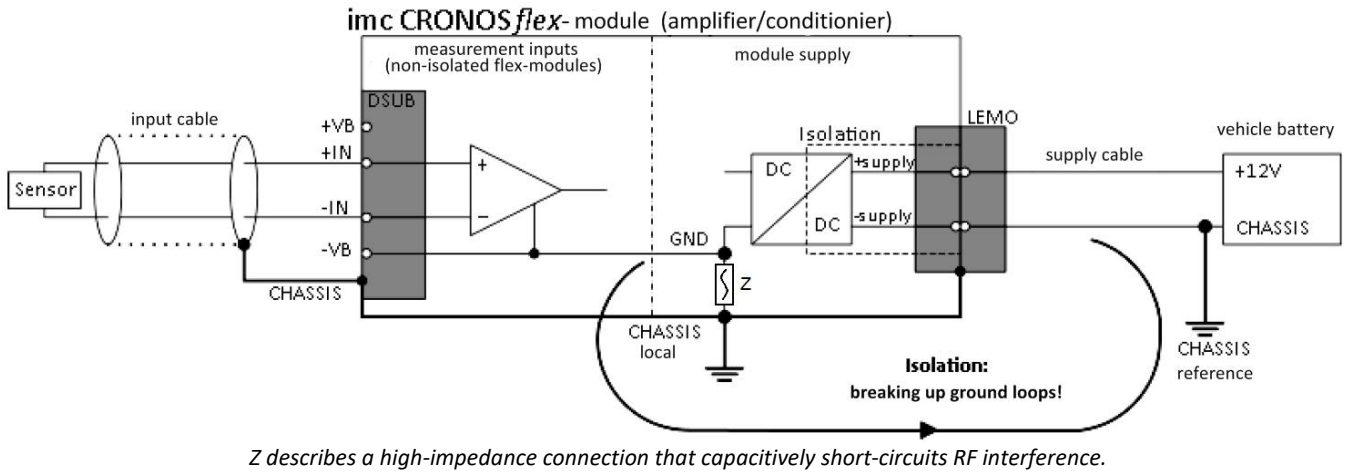

With stationary installations and the use of (already isolated) AC/DC adaptors, any system ground differentials between the device and the central or local power supplies may not be relevant. The big issue in such a case, in contrast to mobile, in-vehicle applications, is from where to obtain a reliable ground voltage. Since it is convenient to use the AC power supply's protection ground line as the ground voltage, the LEMO-terminated AC/DC adaptors for imc CRONOS measurement devices are designed so that the protection ground line is connected all the way through to the LEMO plug's housing, thus securing the device's voltage level to protection ground. Additionally, in the AC/DC-adaptor's LEMO-terminal (not the device's LEMO-socket!), the reference ground of the power adaptor is connected with the housing's (CHASSIS) protection ground: Since the AC/DC power adaptor is already isolating, as is the power input, this supply voltage's reference would not initially be defined and can be set arbitrarily. In particular for reasons of suppressing HF (high-frequency) interference signals stemming from the AC/DC switching power adaptor, direct grounding is normally advisable.

Forced grounding via the AC/DC adaptor's safety ground

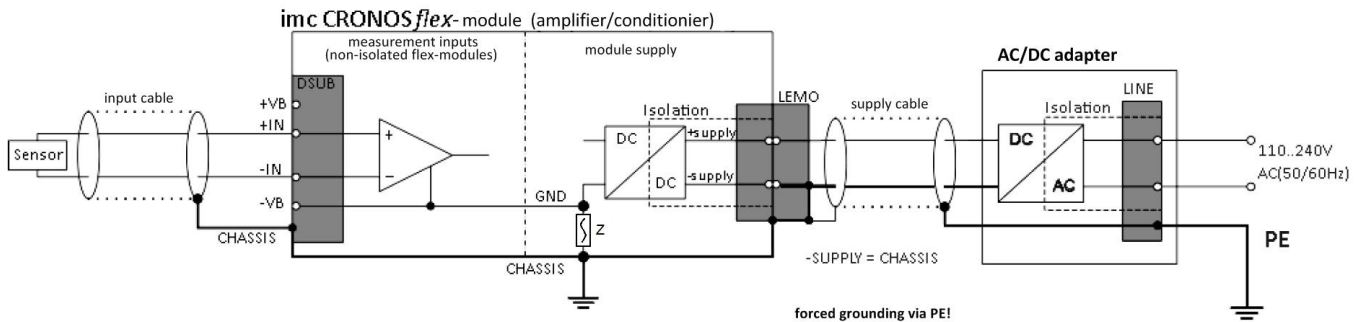

3.14 Power supply options (CRFX)

3.14.1 Overview of power supply options

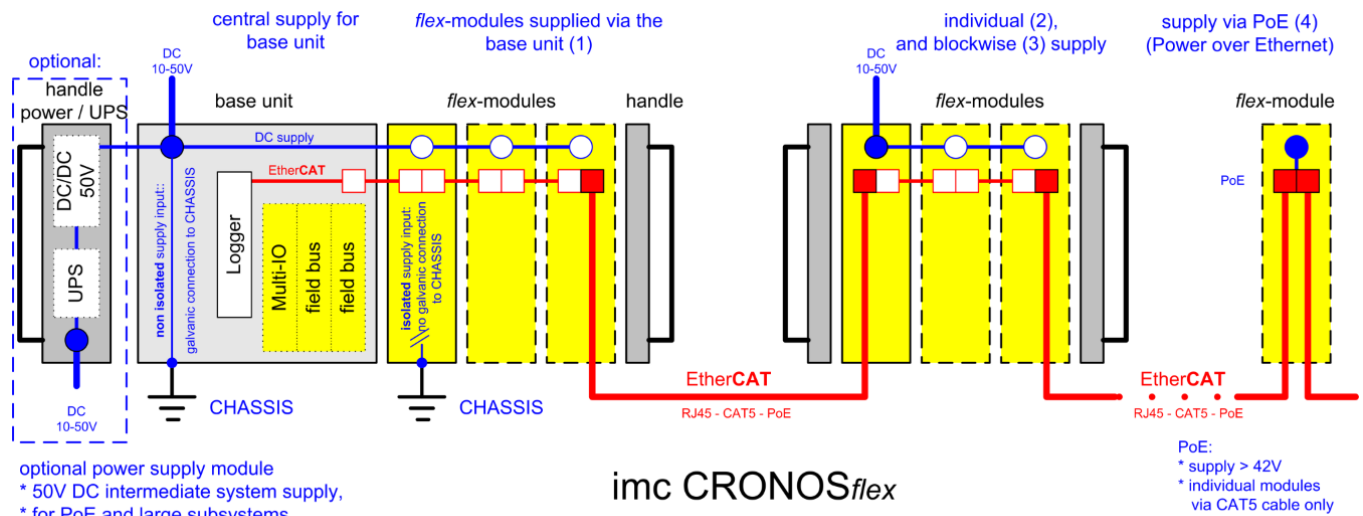

optional power supply module
* 50V DC intermediate system supply,
* for PoE and large subsystems,
* with UPS battery

(1) via the imc CRONOSflex base unit

- for modules directly attached to the base unit
- multiple measurement modules operable at one base unit
- activation/deactivation via central main switch on the base unit
- in particular with low supply voltage and (12 V) and high resulting current, the plugs' maximum current carrying capacity (3.1 A) must be taken into account, which can limit the maximum size of a module block powered in common: max. 37.2 W (12 V)
- an optional supply module in the leftmost carrying handle ensures a common power supply for any size of blocks by providing a constant voltage of 50 V at max. 100 W for any input voltage between 10 to 50 V

(2) individual power supply

- for modules which are connected by CAT5 network cables across a wide area
- 10 V to 50 V DC via LEMO.1B socket
- activation/deactivation by connection of the power supply

(3) joint supply of a module substack

- a block can consist of: a base unit with signal conditioners, a block of purely signal conditioners and/or a block with a power supply module (the Power Handle)
- The power supply for stacked modules must always come via the LEMO-socket through the outer left module (looking at the conditioner terminals, the display and model plaque are on the left), the LEMO terminals of the other modules are then disconnected. A module's LEMO-socket is always deactivated whenever its neighbor to the left is directly connected via a module's plug-in connector. For the supply of the leftmost module within a block, the actual voltage is the higher of either the voltage applied to the LEMO or the voltage passing through the previous block's patch cable.
- activation/deactivation by connection of the power supply
- The maximum block-size depends on how high the supply voltage is (see above).

(4) via the Ethernet network cable

- according Power over EtherCAT (PoEC)









- PoEC – supply is also supported for multiple modules each connected via CAT5 network cables, however not for module substacks
Maximum: 350 mA, corresponding to PoEC power: 16.8 W (48 V) or 17.5 W (50 V)
- activation/deactivation via power supplying module, e.g. central main switch on Base Unit
- minimum supply voltage of the module fed via network cable (base unit or measurement module): 42 V DC (e.g. optional AC/DC power adaptor with 48 V)
- An optional supply module in the left handle provides a constant voltage of 50 V adequate for PoEC, for any input voltages of 10 V to 50 V.
- Standard 230 V AC adaptor for PoEC can be used

3.14.2 Rules governing supply configurations

For the supply of imc CRONOSflex Modules (CRFX) via the LEMO socket, the modules' plug-in (clicking) connectors, or via PoEC, the following rules apply:

- current limit of module plug-in connectors: 3.1 A
- current limit for PoEC via network cable: 350 mA
- The PoEC supply lines are conducted via RJ45, but not via the module connector.
- The local supply for a stacked block of directly connected imc CRONOSflex Modules always comes from the leftmost module's LEMO socket: pin-encoding on the module connector distinguishes which neighboring module is connected "on the left" and blocks the module's own LEMO supply connection.
- A block's leftmost module obtains its power either from its LEMO terminal (which is connected in all cases) or from the voltage at the network cable's (RJ45 network cable's) PoEC line, whichever voltage is greater.

As a result, there are a number of different typical application topologies, presented below. The diagrams used employ the following symbols:

	PoEC Power-connection		LEMO Power-connection		Power supplied via module connector (click)
	module supplied via PoEC (RJ45)		module supplied via LEMO		LEMO feeding the PoEC connection (RJ45)
	module not supplied via PoEC		module not supplied via LEMO		

3.14.3 Directly stacked modules

imc CRONOSflex Modules can be stacked directly using a click-mechanism, thus not requiring extra power supply or cabling. Any signal conditioning modules directly connected to a base unit are jointly activated/deactivated by the base units main switch.

Directly connected imc CRONOSflex Modules with extra device power supply: stacked by "click"-mechanism

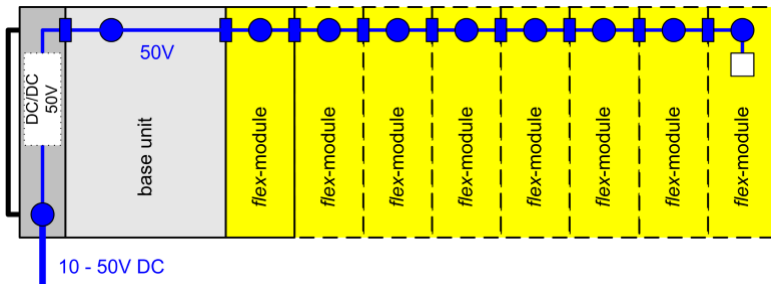

The current-carrying limit on the Module connector also limits the amount of signal conditioning modules which can be stacked directly. The higher the supply voltage is set, the less this limit matters, since the modules' (constant) power consumption leads to correspondingly low currents. The optional supplemental supply unit will convert the 10 V to 50 V input voltage to a fixed intermediate circuit voltage of 50 V at max. 100 W.

Thus, using the supplemental supply unit is the recommended configuration, especially in applications where only low voltage power supply is available (12 V vehicle) and extensive, primarily centrally-concentrated systems are set up.

If the supplemental supply is not used, then the wide-range (10 V to 50 V) rated supply voltage is used to power the modules, which means that at low voltages and correspondingly high currents there may be a maximum size for directly stacked module blocks to observe. However, this constraint by no means applies to the overall system, only to stacked blocks!

A distributed system of multiple, separately powered module blocks connected to each other by network cable is an easy way to circumvent any block-size limitation.

Directly connected imc CRONOSflex Modules without extra device power supply: stacked by "click"-mechanism

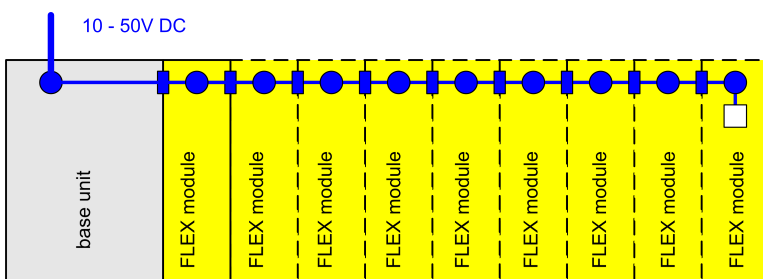

Note

Make sure that the overall power consumption does not pass the available power consumption.



Example

For 24 V, the maximum size of a block is 6 to 11 modules, depending on the module type. For a supply voltage of 12 V (vehicle battery), the limit is about 3 to 5. For each satellite block consisting only of signal conditioners without a base unit, one additional module is allowed, since the first connection carried by the plug-in connector is to the second module.

3.14.4 Overall system consisting of multiple blocks

For various reasons, it may be desirable or necessary to divide up a large block into multiple smaller blocks or even individual modules:



Example

- widely spaced placement in remote locations
- splitting up an unwieldy block into multiple (for instance, stacked) blocks at one central location
- the module connector's current limit (3.1 A) for a contiguous block has been reached, especially in the case of low DC supply voltage (e.g. 12 V in a car)
- the power limit of a DC supply source, for instance, a 60 W AC/DC adaptor has been reached

Distributed, separately supplied blocks of imc CRONOSflex Modules

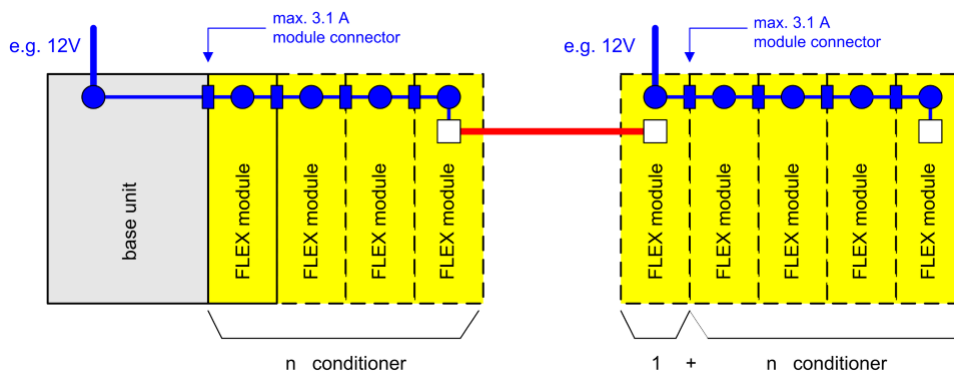

Separately powered individual signal conditioners or conditioner blocks are activated/deactivated by connecting their respective supply voltage. They are not coupled to the base unit's global main switch.

The exact power data for the various conditioner types, and their resulting maximum count of directly stacked modules, appear in the detailed technical specs or in overview table below. Otherwise, a convenient, interactive "Configurator" based on MS Excel is available, with which it is easily possible to check the supply needs and limits of any system topology.

The current at the module connector is prevented from exceeding the current limit by fuses (PTC). The trigger threshold for these fuses is temperature-dependent, and designed that even at maximum temperature, the rated current can be delivered reliably. For this reason, the trigger thresholds at lower temperatures or before the system is fully warmed up are typically higher. In case of overload, any directly connected conditioners are electrically disconnected, but not the base unit providing power, since its supply current is not carried by the module connectors.

3.14.5 Supplemental device power supply (Power Handle)

In order to provide adequate reserve power for any new modules attached, as well as sufficiently high voltage for PoEC operation, the optional power supply module Power Handle is available. As a DC/DC converter, it generates from an input voltage of 10 to 50V a constant, stabilized 50V supply able to power a large block of modules or a complete system.

The central [main switch](#) ²¹ of the connected base unit also indirectly controls the activation/deactivation of the supplemental supply power. The Power Handle does not have a separate pushbutton for activation/deactivation, but instead it has a (LEMO) Remote terminal.

Remotely controlling the main switch of the system's supplemental power supply

As an alternative to manual activation and deactivation by means of the directly attached base unit's main switch, there is another controllable contact available for use at the socket designated "REMOTE". The Remote-Switch contacts respond similarly to the green push button on the base unit: Briefly connecting the signals "SWITCH" and "ON" activates the device, while connecting "SWITCH" with "OFF" deactivates it. Any button or relay contact used for this purpose must be able to conduct approx. 50 mA of current at max. 10 modules. The reference voltage for these signals is the primary power supply.

The signal "SWITCH1" serves to run the device with the switch continuously bridged: When "ON" and "SWITCH1" are connected, the device starts as soon as the external supply voltage is applied. If there is an outage of the supply voltage, the overall device's internal buffering is active for the duration of the buffer time constant set, and then switches off automatically. This operation mode is particularly designed for in-vehicle use, with fixed coupling with the ignition, and without manual control.

The additional contact "MUTE" (6) serves the purpose of muting the internal buzzer if necessary, by bridging the voltage to the reference voltage (5). The buzzer beeps to indicate that the external main power supply has failed and that the system is currently running on the internal buffer battery. This is very helpful for monitoring purposes, but can cause annoyance if acoustics measurements are involved. The beeping only begins 10 sec before elapse of the buffer time constant, meaning "soon" before the impending forced deactivation and (as of Revision 2 of the modules) can be completely suppressed by means of the MUTE signal. Before that, or in cases when longer time constants are set, reflecting typical applications of independent battery power, the beeping is suppressed as a rule, since it is usually not desired (similarly to a battery-powered Notebook).

Supplemental device power supply (CRFX-HANDLE-POWER) for system power supply by means of 50 V intermediate circuit

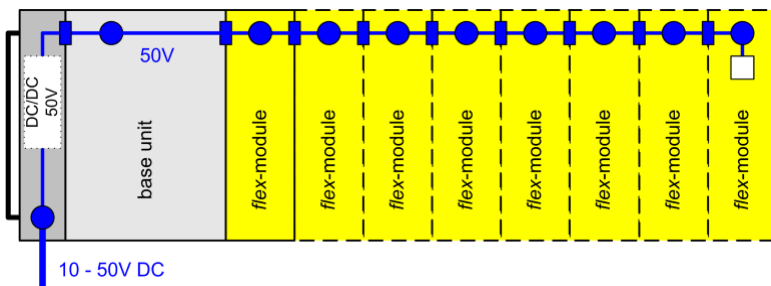

Note

Make sure that the overall power consumption does not pass the available power consumption.

Supplemental device power supply for remotely installed conditioner block

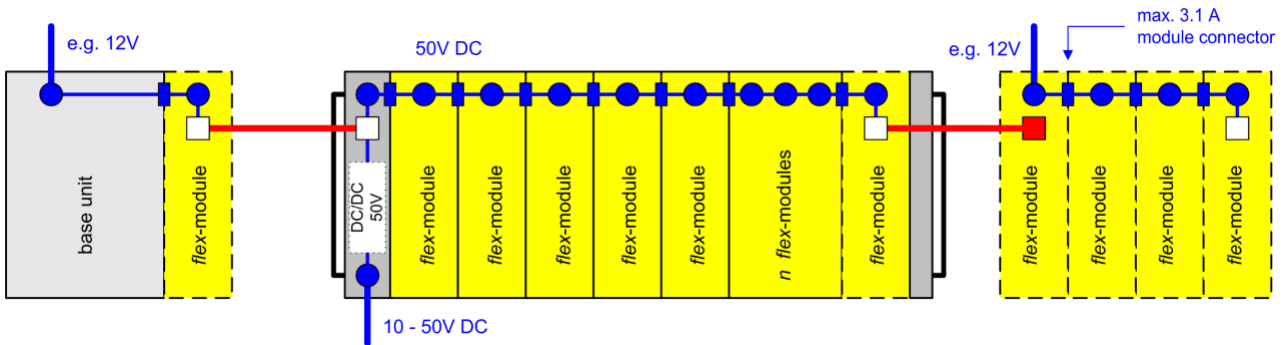

In conjunction with the supplemental power supply, a block only of conditioners can be activated not only by connecting the local power supply, but remote activation can be achieved by means of the connecting network cable. This means that this isolated island of modules can also be switched on/off by the base unit's main switch. However, this only applies to contiguous blocks powered by the supplemental supply.

When the supplemental supply is used and a large block is subdivided into multiple smaller blocks which are each to be supplied separately, then it depends on the size of these blocks whether they can be directly run on lower supply voltage (smaller blocks), or whether (in the case of larger blocks) they require higher voltage. In such cases, multiple parallel 50V output socket on the supply unit makes it possible to use them to supply additional satellite blocks with five 4-pin LEMO sockets on the rear side of the handle to supply additional satellite blocks.

Reference

Please [see the pinout here](#) of the: Additional output supply sockets: LEMO 1B.304

Supplemental device power supply can supply multiple blocks

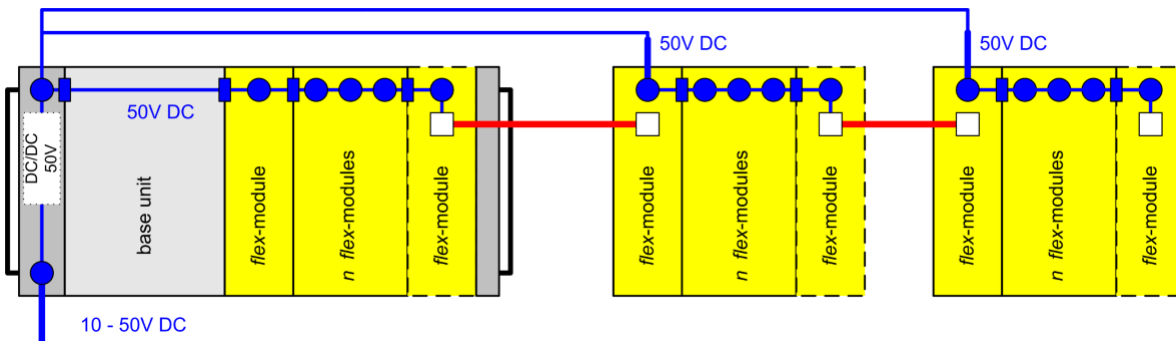

3.14.6 Overview of available operation and remote control modes

The power supply module (Power Handle) does not have its own main switch, but can be switched on/off in three ways:

- Manual main switch of a connected base unit
- REMOTE-terminal on the Power-Handle
- A controlling PoEC voltage delivered from outside to the Power-Handle's RJ45 jack "IN" (particularly for operating a blocks of dedicated conditioner modules, without a base unit!)

In conjunction with a connected base-unit, deactivation is not accomplished directly but instead always by means of a "Shutdown"-signal communicating with it. This provides both the ability to stop the measurement in a controlled way and reliable conclusion of data saving to the device, and thus total data integrity.

In consequence, the following possible scenarios lead to activation of the Power-Handle and the module block connected to it:

- The base unit whose push button is pressed is connected (regardless of the base-unit's Remote terminal!),
- a push button connected to the Power-Handle's Remote terminal ("SWITCH") is pressed,
- an external power supply (LEMO) is applied and a switch connected to the Remote terminal is closed ("SWITCH1"),
- an external power supply (LEMO) is applied, and additionally, a PoEC voltage higher than 3V is applied at the Power-Handle's EtherCAT terminal ("IN").

The power supply module switches itself off under the following conditions:

- The base unit is connected and after having been active it has been powered down and has deactivated itself. This in turn may be initiated in particular when, after an outage of the external power supply, the UPS buffer duration has elapsed and the base-unit has received a "Shutdown"-command from the Power-Handle.
- No base-unit is connected but only conditioning modules, and the voltage level of a PoEC voltage applied at the Power Handle's EtherCAT terminal ("IN") falls to below 2V.
- No base-unit is connected; sudden deactivation upon elapse of the UPS buffer duration in case of UPS operation, or in response to pressing the push button or throwing the Remote-terminal's switch.
- The Reset button on the front panel is pressed.

Note

During operation, a base-unit connected to the power supply unit receives a Shutdown-command if:

- a push button connected with the module's own Remote terminal is pressed,
- a switch connected with the module's own Remote terminal is opened, or
- in case of UPS operation, the UPS-buffer duration has elapsed.

3.14.7 Charging the internal battery of a Power-Handle having UPS-functionality

System power supply units (Power-Handles) having additional UPS functionality, i.e. an internal buffer battery, only charge up the battery if they are switched on. This is by intentional design, in particular for purposes of in-vehicle applications, in order to prevent accidental draining of a vehicle battery due to the considerable current draw for charging.

Therefore, if a Power-Handle having a UPS battery is to be charged separately from its measurement system, for instance in preparation for the buffer or in order to refresh it, by means of an AC/DC adaptor, while the rest of the system remains in the vehicle, then this Power-Handle module must be activated in "Stand Alone" mode. Since it doesn't have its own manual main switch, this can be accomplished by means of its REMOTE-terminal's remote control signals, for instance by bridging Pins 1 and 2.

Terminal connection Power-Handle:**(CRFX/HANDLE-POWER, CRFX/HANDLE-UPS-L, CRFX/HANDLE-LI-IO-L)**

- Power supply LEMO.EGE.1B.302 (female) multicoded
- Auxiliary output 5x LEMO.1B.304 (female)
(rear side of the handle)
- System bus (EtherCAT): RJ45 Buchse (EtherCAT IN)
- Remote control: LEMO.1B.306 (female)
- Module socket: 20 pin (System bus and power supply)

Position	Buffer duration
0	none
1	1 sec
2	2 sec
3	5 sec
4	10 sec
5	30 sec
6	1 min
7	2 min
8	5 min
9	10 min
A	30 min
B	1 h
C	2 h
D	5 h
E	10 h
F	maximum

The Power Handle provides the functioning of the overall system including all additional modules even during a power outage, thanks to battery buffering. UPS buffering is available with either lead batteries (CRFX-HANDLE-UPS-L) or Li-ion batteries as well as with extended battery capacity (CRFX-HANDLE-LI-IO-L). The supply module is protected by a non-resettable 20 A fuse at its input.



Both handles (CRFX-HANDLE-LI-IO-L and the CRFX-HANDLE-UPS-L) are equipped with a switch to set the buffer duration (table).

¹ no use with imc EOS

Short-circuit proof

Since theoretically any amount of imc EOS and imc CRONOSflex Modules could be connected to the supply module, the supply module comes with a power limiting circuit with long-term short-circuit protection. This circuit limits the power consumed to approx. 100 W.

When this limit is surpassed, the output voltage is cut, and then is enabled again after about 4 seconds. If the overload or short-circuit has still not subsided by that time, the system wait another 4 seconds etc. During the "waiting period", the supply module's Power-LED flashes at one-second intervals. The LED, designated "**LIMIT**" at the front of the Power Handle, is yellow if the output power consumption is more than 80 W and the LED will be red if the power consumption is more than 95 W.

Note

- The LED, designated "POWER" at the front of the Power Handle, is yellow in case of an operation in battery mode.
- If the Power Handle is connected to a imc EOS or a CRFX base unit please make sure that the LEMO supply socket is connected with the Power Handle! The supply of a block of modules always comes from the leftmost module (first module).



Reference

The meaning of the LEDs are described in the manual chapter: "Rechargeable accumulators and batteries".

3.14.8 Power over EtherCAT operation

imc CRONOSflex Modules can also be powered just from the network cable (EtherCAT-system bus), without any separate supply source. For this purpose a minimum voltage of 42 V is required, with a maximum current of 350 mA to be delivered.

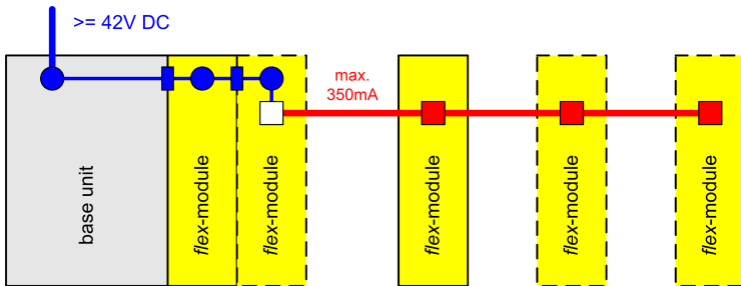
PoEC - Supplying imc CRONOSflex Modules only via the network cable, without separate power source



Depending on the power consumption of the module type used, up to three imc CRONOSflex Modules can be powered jointly. The overview table below states the respective power consumption specs.

Since the PoEC supply lines are only available with at the RJ45 sockets, but not at the module plug-in connectors, multiple PoEC-powered

modules must be mutually connected with network cables and not directly clicked together.

PoEC - Supplying of imc CRONOSflex modules:

Instead of "snapping on", connection via network cable

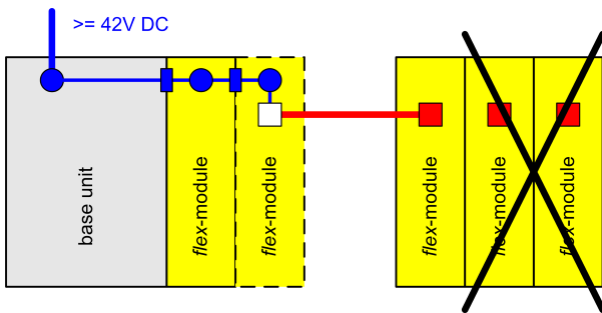

PoEC-supply of one or more modules ensures indirect activation/deactivation through the supplying unit and thus, for example, remote switching by the base unit's main switch.

Since a minimum voltage of 42 V is required for the use of PoEC, the supplemental power supply can make this possible, if (for example on board a vehicle) the available voltage is insufficient, or if no 48 V AC/DC adaptor can be used.

Supplemental device supply for use of PoEC with low supply voltage

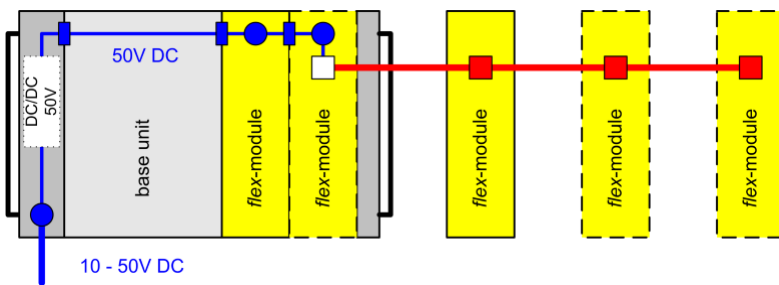

Note

The imc CRONOSflex CRFX/WFT-2 module does not support the PoEC operation.

3.15 Overview power consumption

		Power supply / max. number of modules						
		direct click connection				PoE		
		n x CRFX	KFZ	AC/DC	AC/DC	CRFX/POWER	AC/DC	PoE, 48V
V_DC P_max	12,0 V		15,0 V	24,0 V	50,0 V	48,0 V	48,0 V	50,0 V
imc CRONOSflex Module	P							
CRFX/LV3-8	6,4 W	5,8	7,3	11,6	15,6	23,3	2,6	2,7
CRFX/LV3-8 + ICP-Plug	8,8 W	4,2	5,3	8,5	11,4	17,0	1,9	2,0
CRFX/LV3-8 + SUPPLY	12,4 W	3,0	3,8	6,0	8,1	12,0	1,4	1,4
CRFX/UNI2-8	10,1 W	3,7	4,6	7,4	10,0	14,8	1,7	1,7
CRFX/DCB2-8 / B8	10,0 W	3,7	4,7	7,4	10,0	14,9	1,7	1,8
CRFX/ISO2-8	7,0 W	5,3	6,6	10,6	14,2	21,2	2,4	2,5
CRFX/ISO2-8 + ICP-Plug	9,2 W	4,1	5,1	8,1	10,9	16,2	1,8	1,9
CRFX/ISO2-8 + SUPPLY	12,4 W	3,0	3,8	6,0	8,1	12,0	1,4	1,4
CRFX/ISOF-8	8,8 W	4,3	5,3	8,5	11,4	17,0	1,9	2,0
CRFX/ISOF-8 + ICP-Plug	10,9 W	3,4	4,3	6,8	9,2	13,7	1,5	1,6
CRFX/UNI-4	7,0 W	5,3	6,6	10,6	14,3	21,3	2,4	2,5
CRFX/UNI4 + SUPPLY (120R)	8,5 W	4,4	5,5	8,8	11,8	17,5	2,0	2,1
CRFX/UNI4 + SUPPLY (0,5W)	10,8 W	3,4	4,3	6,9	9,3	13,8	1,6	1,6
CRFX/HV-4U	5,8 W	6,4	8,0	12,8	17,2	25,5	2,9	3,0
CRFX/HV-2U2I	5,8 W	6,4	8,0	12,8	17,2	25,5	2,9	3,0
CRFX/HISO-8	7,3 W	5,1	6,4	10,2	13,7	20,4	2,3	2,4
CRFX/BR2-4	9,3 W	4,0	5,0	8,0	10,8	16,0	1,8	1,9
CRFX/ICPU2-8	7,4 W	5,0	6,3	10,1	13,6	20,2	2,3	2,4
CRFX/AUDIO2-4	7,4 W	5,1	6,3	10,1	13,6	20,2	2,3	2,4
CRFX/HRENC-4	7,4 W	5,0	6,3	10,1	13,5	20,1	2,3	2,4
CRFX/DI2-16	3,9 W	9,6	12,0	19,2	25,9	38,5	4,3	4,5
CRFX/DI2-16 + SUPPLY	4,7 W	7,9	9,9	15,8	21,3	31,7	3,6	3,7
CRFX/DI2-16-DO-16-HC	4,3 W	8,7	10,9	17,4	23,4	34,9	3,9	4,1
CRFX/DI2-16-DO-16-HC + SUPPLY + LOAD	7,8 W	4,8	6,0	9,6	12,9	19,2	2,2	2,3
CRFX/DI2-32	4,4 W	8,5	10,6	16,9	22,7	33,8	3,8	4,0
CRFX/DI2-32 + SUPPLY	6,1 W	6,1	7,7	12,3	16,5	24,5	2,8	2,9
CRFX/DI-16-HV	3,9 W	9,6	12,0	19,2	25,9	38,5	4,3	4,5
CRFX/DO-16-HC	3,7 W	10,0	12,5	19,9	26,8	39,9	4,5	4,7
CRFX/DO-16-HC + LOAD	6,4 W	5,8	7,3	11,6	15,6	23,3	2,6	2,7
CRFX/DO-16-HC-DAC-8	7,1 W	5,3	6,6	10,5	14,2	21,1	2,4	2,5
CRFX/DO-16-HC-DAC-8 + LOAD	11,7 W	3,2	4,0	6,3	8,5	12,7	1,4	1,5
CRFX/DO-32-HC	4,1 W	9,0	11,3	18,0	24,2	36,0	4,1	4,2
CRFX/DO-32-HC + LOAD	9,5 W	3,9	4,9	7,9	10,6	15,7	1,8	1,8
CRFX/DAC-8	6,7 W	5,6	7,0	11,2	15,0	22,3	2,5	2,6
CRFX/DAC-8 + LOAD	8,7 W	4,3	5,4	8,6	11,5	17,2	1,9	2,0
Min		3	3	6	8	12	1	1
Max		9	12	19	26	39	4	4

 **Note**

- Due to the flexible combinations, the number of supported modules is defined with one position after decimal point.
- A maximum length of 85 cm of attached (clicked) modules should not be passed! Mounting elements can be used for more stability.

3.16 Internal system-bus: Network cables

For connecting the imc CRONOSflex base unit and multiple imc CRONOSflex Modules together to form a single imc CRONOSflex system, besides the power supply an internal system bus is necessary. It is based on standard network hardware and the real-time -Ethernet protocol "EtherCAT". The bus has a line-shaped topology where each module has both an input and output terminal to the bus. For modules directly stacked by the click mechanism, the bus as well as the supply lines is connected by means of the modules' plug-in connectors. Accordingly, for the EtherCAT bus the system features priority and blocking circuitry, which only enables the RJ45 network terminals provided for external cabling if no directly docked module is detected. Indicator LEDs on the network sockets support the wiring process and status diagnostics.

Network terminals and status LED on the rear module panel

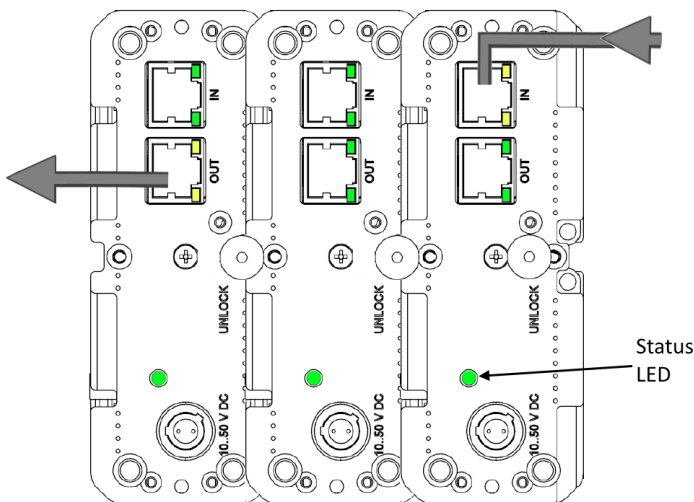

Constant yellow lights on the terminals indicate the system expects connection of an external network or patch cables, where the bus line originating at the base unit is connected at "IN" terminals and the line leading outward to any further bus subscribers is connected to the "OUT" terminal.

The last imc CRONOSflex Module in the system's "OUT" terminal then stays unoccupied; the bus is not circuited as a ring.

Green flashing terminal lights indicate bus activity, not necessarily in the sense of actually proceeding measurement but also in the sense of previously started modules which have recognized the neighboring modules to which they are connected either via external cables or by direct module stacking. In this case, the respective green-blinking RJ45 sockets are empty, and no longer occupied by cables.

Status LED

- Normal operation: the Status LED shines green
- Error: LED shines red!
(possible causes: problems communicating with the ECAT master, or ESD problems.)
- Power ON/reboot: LED first shines yellow, then red, then the status LED flashes green for approx. 5 s, then the initialization phase starts
- Initialization phase: LED flashes for approx. 10 s to 15 s yellow;

subsequently normal operation should be indicated by constant green shining

3.17 CRFX/ETHERCAT-GATEWAY

The imc CRONOSflex EtherCAT Gateway is a bus coupler that allows a number of imc CRONOSflex amplifier modules to be used within an EtherCAT-based automation or control system. imc amplifier components can thus be used in EtherCAT environments such as Beckhoff TwinCAT or MTS FlexTest, for example, without the need for a complete CRONOS data logger system (with base unit).

3.17.1 Application

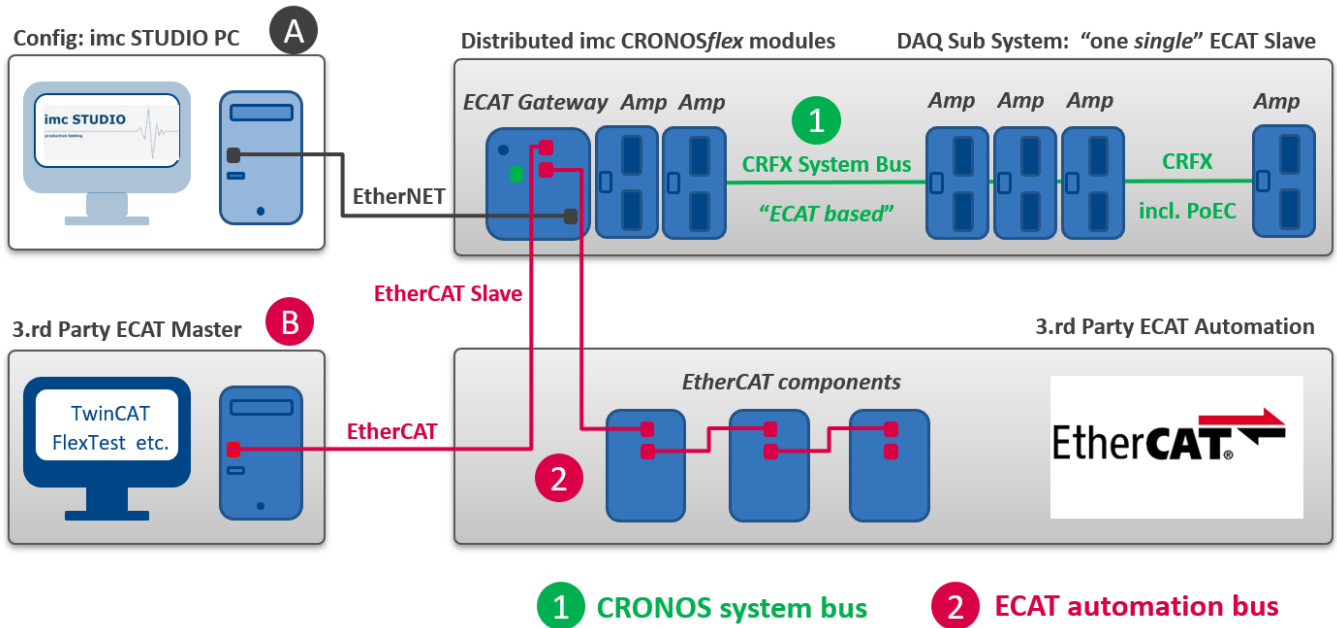

- A Configuration** Configuration of the imc sub system via imc STUDIO Software (PC via EtherNET)
 - Output ESI and A2L: Information for the EtherCAT Master
 - subsequently: connection no longer required (PC, imc STUDIO): **Auto-Start Mode**
- B DAQ operation** Data acquisition operation via "external" EtherCAT test automation system (e.g. TwinCAT Master) → no redundant parallel data acquisition via imc STUDIO

In connection with the gateway, the CRFX modules act as a data acquisition subsystem in the sense of an EtherCAT slave, without operating in the network of a complete CRONOS data logger. The individual modules are interconnected via the CRFX system bus. This CRONOS system bus is based on the "EtherCAT standard", uses network hardware and is spatially distributable via network cables (Power-over-EtherCAT). The protocol of the CRONOS system bus differs from the "EtherCAT Standard". It is not compatible with EtherCAT 3rd party systems, i.e. the CRFX modules cannot be operated in such an environment. The ECAT gateway establishes this connection, forming a single EtherCAT slave station.

The ECAT slave subsystem is configured once using imc STUDIO via EtherNET. Afterwards and during active operation this access is no longer necessary.

Typical applications are:

- Test benches
- Integration of CRFX modules in EtherCAT system environment, such as:
 - TwinCAT automation
 - MTS FlexTest
 - Horiba STARS Engine
 - FEV MORPHEE
 - Instron
- Use of WFT measurement wheels via CRFX/WFT-2 interface module in 3rd party environment

If the target systems implement real-time control, the resulting latencies (signal propagation times) of the system must be taken into account in addition to the sampling rates of the amplifiers (max. 5 kHz) and cycle times of the EtherCAT bus (e.g. 5 kHz or 1 kHz). These are in the order of <2 ms.

3.17.2 Configuration via imc STUDIO

The gateway and the connected modules are configured via imc STUDIO. For this purpose, an Ethernet connection between the gateway and the STUDIO PC must be established.

This configuration and also the Ethernet connection is typically required only once. After that the autostart functionality of gateway and amplifiers can be used. The last valid configuration stored in the device is then automatically loaded when the device is switched on and operation is started.

During configuration, the measuring channels must be set to the desired measuring mode, measuring range, etc.

For the filter setting AAF (automatic anti-aliasing) is to be selected and thereby the sampling rate of the channels is to be set exactly to the rate which is used on the EtherCAT bus as bus cycle, typically either 5 kHz or 1 kHz. Exactly then the AAF filter frequency is matched to the internal cycle rate of the data or pv variable corresponding to the bus cycle.

The actual update rate and thus the effectively utilized EtherCAT bus rate is limited to 5 kHz. If the EtherCAT bus cycle should be selected faster, then the internal rate of max. 5 kHz must still be configured at this EtherCAT gateway during channel configuration. With this rate actually new data are delivered at the bus and also the AAF filter must be adjusted to this rate.

Following the configuration, an A2L file must typically be exported. This file is used to configure the EtherCAT master system. After finishing the configuration, an Autostart configuration must be uploaded to the device (Diskstart), see imc STUDIO manual.

Key data

- Max. ECAT bus cycle: 5 kHz (200 µs), supported bus cycle: 5 kHz, 1 kHz, 500 Hz, 200 Hz, 100 Hz
- Max. number of channels respectively sampling rates:

34 channels @ 5 kHz	(170 kHz sampling rate)
128 channels @ 1 kHz	and lower

4 Maintenance and servicing

4.1 Maintenance and servicing

imc recommends performing a service check every 12 months. An imc service check includes system maintenance in accordance with the service interval plan as specified by the manufacturer and a complete function test (maintenance, inspection and revision).

Maintenance (*repair*) work may only be carried out by qualified personnel from imc Test & Measurement GmbH.

For service and maintenance work, please use the [service form](#) that you download from our website and fill out: <https://www.imc-tm.com/service>



Reference

Device certificates and calibration protocols

Detailed information on certificates, the specific contents, underlying standards (e.g. ISO 9001 / ISO 17025) and available media (pdf etc.) can be found on [our website](#), or you can contact us directly.

4.2 Cleaning

- Always unplug the power supply before cleaning the device. Only qualified service technicians are permitted to clean the housing interior.
- Do not use abrasive materials or solutions which are harmful to plastics. Use a dry cloth to clean the housing. If the housing is particularly dirty, use a cloth which has been slightly moistened in a cleaning solution and then carefully wrung out. To clean the slits use a small soft dry brush.
- Do not allow liquids to enter the housing interior.
- Be certain that the ventilation slits remain unobstructed.

4.3 Storage

As a rule, the measurement device can be stored at temperatures ranging from -40°C to +85°C.

4.4 Transport

When transporting, always use the original packaging or a appropriate packaging which protects the device against knocks and impacts. If transport damages occur, please be sure to contact our tech support. Damage arising from transporting is not covered in the manufacturer's guarantee. Possible damage due to condensation can be limited by wrapping the device in plastic sheeting. The represented handling label for lithium ion batteries can be attached also independently printed on the package (e.g. by gluing on the package or in a transparent unlabeled document bag). Note however that the form and the format are accurately given by IATA and the expression has to take place in color. Format: 120 x 110 mm.

Lithium Battery Handling Label:
UN 3480 / UN3481



5 Start of operation Software / Firmware

5.1 Installation - Software

The associated measurement engineering software imc STUDIO, the configuration and operating interface for all imc instruments, provides the devices with exceedingly versatile functionality. It achieves comprehensive total solutions for everything from laboratory tests through mobile data logger application all the way to complete industrial test stations.

Use of the software requires a license, subject to the purchase order and configuration (see e.g. imc STUDIO manual product configuration / license).

In order to be able to install or uninstall imc STUDIO products, you must be registered with a user account possessing administrator rights to the PC. This applies to the overwhelming majority of all installations of Windows. However, if you are only logged on to your PC without administrator rights, log off and log back on with an administrator user account. If you do not possess an administrator user account, you will need the support of your system administrator or IT department.

You will find a detailed description to the installation of the software in the adequate manual or getting started.

5.1.1 System requirements

The minimum requirements of the PC, the recommended configuration for the PC, the supported operating system are mentioned in the data sheets and the imc STUDIO manual.

5.2 Connect the device

There are multiple ways to **connect the imc measurement devices with the PC**. In most cases, the **connection via LAN** (local area network, Ethernet) is implemented. See section "[Connecting via LAN in three steps](#)"^[50] for the **quickest way to connect** PC and measurement device.

But there are also other connection types:

- WLAN
- LTE, 4G, etc. (via appropriate routers)

These are described in a separate chapter in the software manual: "*Special options for connecting to the device*".

The devices use the **TCP/IP protocol** exclusively. With this protocol, some settings and adaptations for your local network may be necessary. For this purpose, the support of your network administrator may be necessary.

Recommended network configuration

The latest and high-performance network technologies should be used to achieve the maximum transfer bandwidth. This means especially 1000BASE-T (GBit Ethernet). GBit Ethernet network devices (switches) are downward compatible, so that imc devices that only support 100 MBit Fast Ethernet can also be operated on them.

The cable length between the switch and a PC or a device should be less 100 m. Use a shielded cable. If the length of 100 m is exceeded, then you have to insert another switch.

If the system is being integrated into an existing network, you must ensure that the minimum data rate can be guaranteed. Under some circumstances, this may require using switches to subdivide the network into separate segments in order to govern the data traffic in a targeted way and thus optimize the data rate.

In very demanding applications, you might consider grouping multiple GBit Ethernet devices via even higher-performance sections lines of the network (e.g. via 5 GBit Ethernet) and to connect these groups to NAS-components, for instance, via these lines.

When such imc devices are included which use network-based PTP-synchronization (e.g. CRXT or CRFX-2000GP), then it is necessary to use network switches which fully support this protocol on the hardware side. Appropriate network components are also available as imc accessories (e.g. CRFX/NET-SWITCH-5) and are then electrically and mechanically fully compatible with the imc systems.

5.3 Connecting via LAN in three steps

The most common case is described below: the PC and the device are connected via cable or network switch. The device's IP address must be set in the PC's address range. Subsequently, the device can be connected with the PC. If a connection has ever been established previously, the software recognizes the device's hardware configuration. In that case, experiment configurations can be prepared without any connection to the device.

Step 1: Connecting the measurement device

To connect via LAN there are two options:

1. The measurement device is connected to an **existing network**, e.g. via network switch. Only with a switch is it possible to run multiple devices.
2. The measurement device is connected directly to a network adapter on the PC (**point-to-point**).

In a LAN, the first case is typically implemented. Modern PCs and network switches are usually equipped with Auto-MDI(X) automatic crossover recognition, so that it is not necessary to distinguish between crossed and uncrossed connection cables. Thus both cable types can be used.

Step 2: IP-configuration

Start imc STUDIO. Click the "Device interfaces" button () to open the dialog for configuring the IP address of the device.

Ribbon	View
Setup-Configuration > Device interfaces ()	Complete

If this **button** is **not present** in the view, it is also possible to open the dialog after a device search if it failed to find any new devices. Subsequently, a prompt appears asking whether to search for devices with an inappropriately configured network interface. Close this message box by clicking "Yes".

Once the dialog starts, the system automatically searches for all devices in the network. In the tree diagram, all available devices are indicated. If the device appears among the group "Currently not reachable" ①, it is necessary to modify the device's LAN-settings. If the device appears among the group "Ready for measurement" ②, you can leave the settings as they are or review them.

Select the device for making modifications ③.

If there is any IP-conflict, devices affected will not be listed.

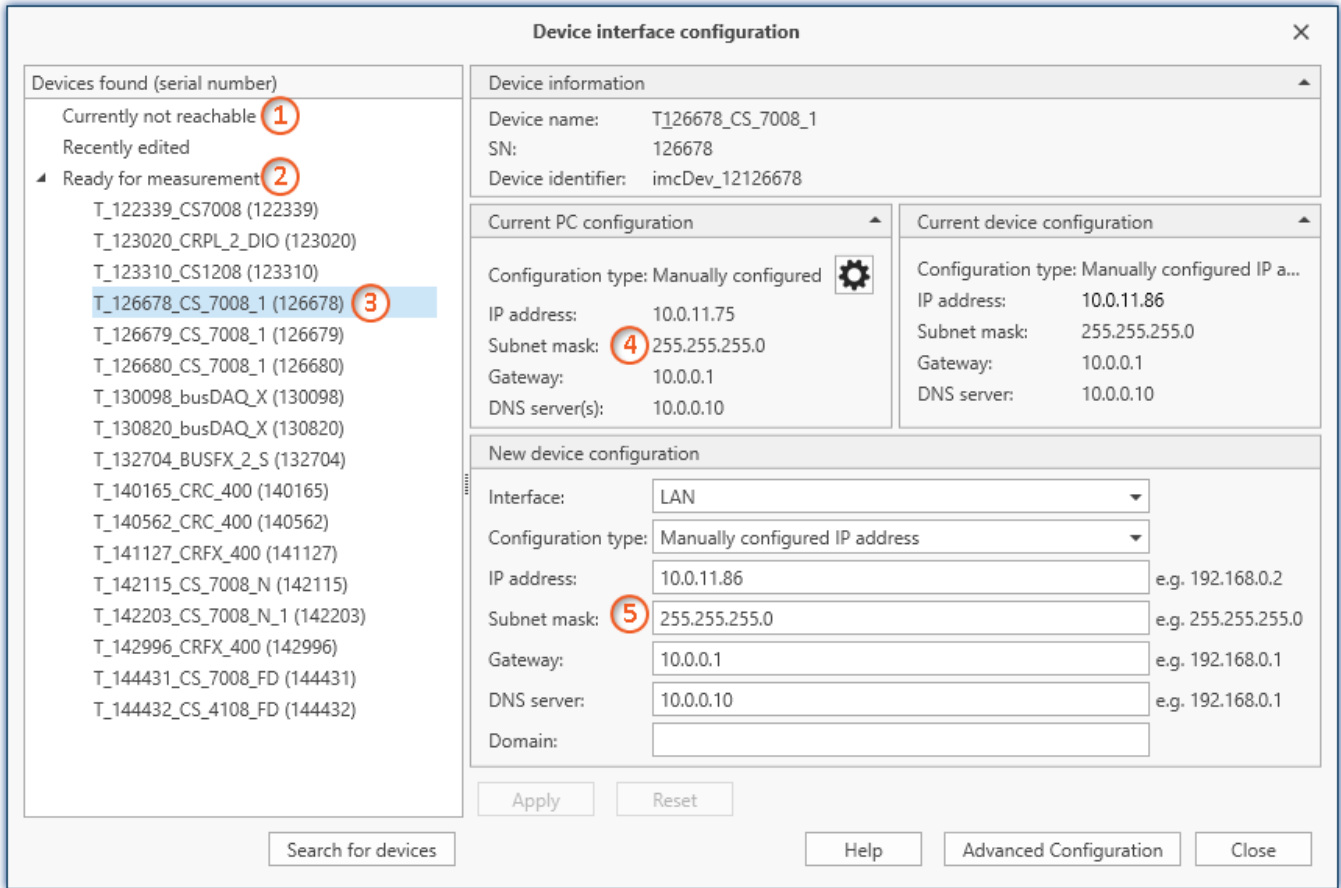

Display of measurement devices found and of the IP address

Set the **IP address manually** if you are not using DHCP. The device's IP address ⑤ must match with the PC's address ④. To conform to the network mask, only the device portion may be different (see example).

Example

In the example shown, the fixed IP 10.0.11.75 with subnet mask 255.255.255.0 is selected for the PC. For measurement devices, any numbers would be suitable which begin with 10.0.11. and then do not contain 0, 75, or 255. The 0 and the 255 should not be used, if possible, due to their special significance. The 75 is the computer's number.

Example for IP settings	PC	Device
IP address	10 . 0 . 11 . 75	10 . 0 . 11 . 86
Network mask	255 . 255 . 255 . 0	255 . 255 . 255 . 0

If the configuration type: "DHCP" is used, **the IP address is obtained automatically** from the DHCP-server. If it is **impossible to obtain any setting values** via DHCP, the **alternative values are used**. These could lead to errors in the connection (different networks, same IP addresses, etc.).

If there is a **direct connection** between the device and the PC by a cable, then **DHCP should not be used**.

In order to apply the changes, click on the button "Apply". Wait for the device to restart and then close the dialog.



Note

Connection via modem or WLAN

If the connection to the device is established via a modem or WLAN, start the program "imc DEVICES Interface Configuration" by clicking on the button: "Advanced Configuration" (see previous figure). An exact description is found in the software manual chapter: "Setting Up - Connect the device" > "Special options for connecting to the device".

Step 3: Integrating a device into an experiment

Now you are ready to add the device to the imc STUDIO experiment. If your device is unknown to the system, first perform the "device search".

Ribbon	View
Home > Search for devices ()	all
Setup-Control > Search for devices ()	Complete

Select the desired device: Once you click in the checkbox "Selected" for the desired device, it is ready to use in the experiment.

Selected	Device name	SN	Device specification
<input checked="" type="checkbox"/>	T_124835_C1_1_LEMO_ET	124835	imc C1-1 LEMO
<input type="checkbox"/>	T_130039_busDAQ_X	130039	busDAQ-X
<input type="checkbox"/>	T_130311_SPARTAN_U32_CAN	130311	imc SPARTAN

You can also select multiple devices for your experiment.

Now the device is "known". After the next program start it is available for selection. For further information, see the documentation on the component "Setup".

Reference

Time zone

Now check whether the correct time zone is set for the device. For more info, see the description of the software manual under the keyword "Device properties".

5.4 Firmware update

Every software version comes with matching firmware for the hardware. The software only works with devices having the right firmware.

Once the program connects up with the unit, the device's firmware is checked. If the software version doesn't match the device's firmware version, you are asked if you want to perform a firmware-update.

Note

The firmware update is only required if the software was obtained as an update. If you obtained your hardware equipment together with the software, no firmware update is necessary.

Warning

Do not interrupt the firmware update!

Be absolutely certain to observe the following:

1. Under no circumstances should the device or its power supply be deactivated during the firmware update!
2. The network connection may not be interrupted. Use a cable connection, not WLAN!

Depending on the device type, the following components are loaded automatically: Interface-firmware (Ethernet, modem, ...), booting program, amplifier firmware, firmware for the signal processors.



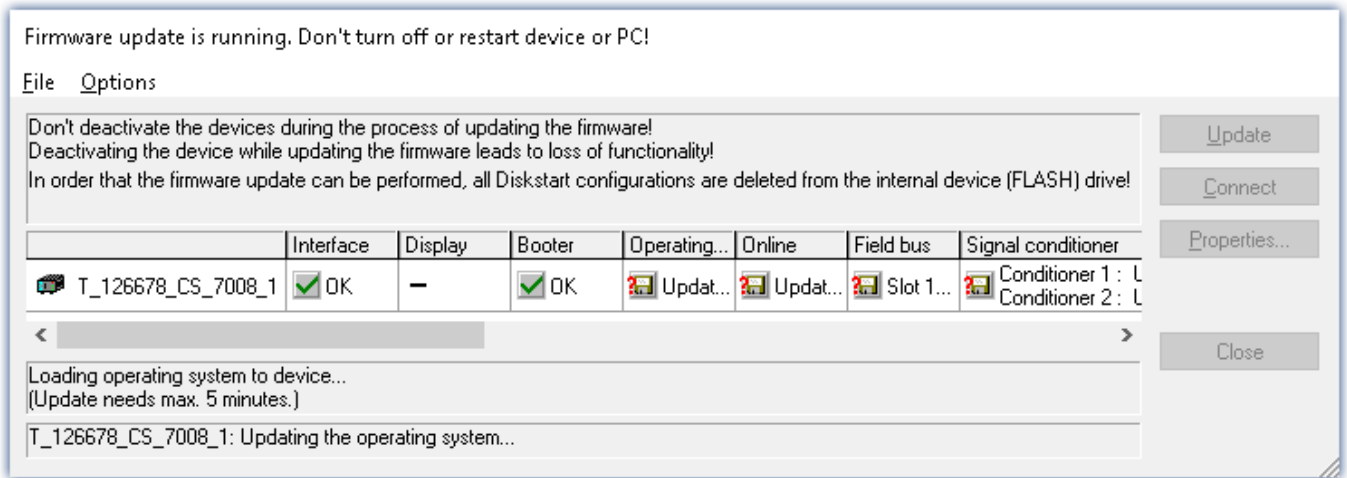

The dialog for the firmware-update looks like this:



*Start of the firmware update (example of a single device)
The state of the components of the firmware is displayed in the list.*

Component	Description
Interface	Interface-Firmware (Ethernet)
Booter	Start-up program for the device upon switching-on
Operating system	Device operating system
Online	Online-functions and hard drive controller
Display	Operating system of the connected displays
Fieldbus	Fieldbus interfaces (e.g. CAN etc.)
Signal conditioners	Amplifiers

The following symbols for the individual firmware components appear in the list:

Symbols	
	not current
	firmware conforms to current standards
	error occurred during update procedure
	this option is not available on the device

If no status indicators are displayed, no connection could be made to the corresponding device.

The duration of the update depends on the number of amplifiers (can last up to several minutes). You will be informed on the progress.

You are notified when the firmware setup concludes successfully, as shown below:

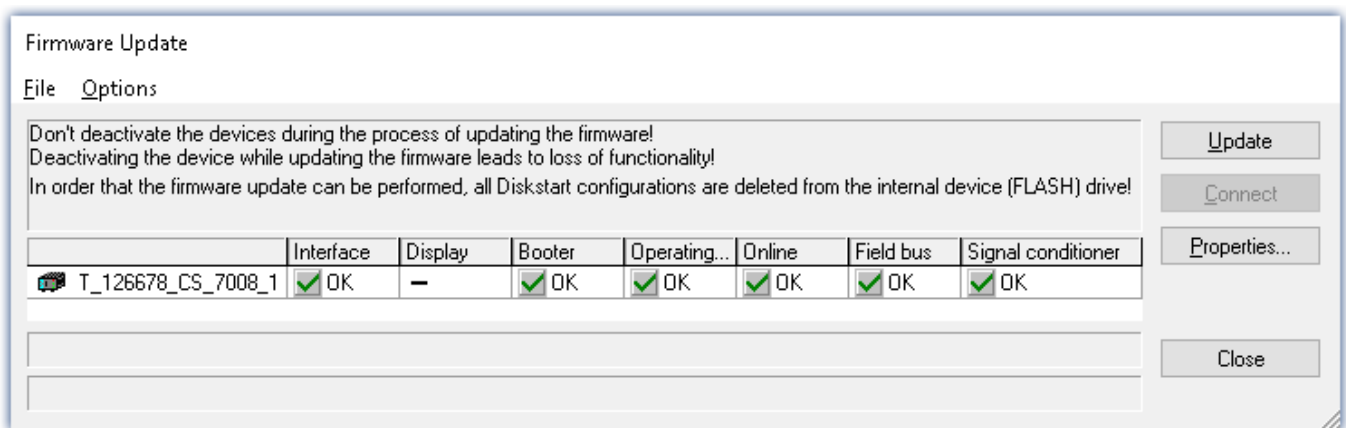

Conclusion of the firmware update (example of a single device)

Choose "Close". The device can now be used with the product software.

**Warning****Be sure to observe in case of error**

- For a variety of reasons, the firmware update sometimes does not conclude properly, for example due to interruption of the power supply. For instance, the "handshake signal" at the end of the procedure may be missing. In this case, no measurement channels would be displayed initially. However, restarting the device and its software and performing the firmware update again usually restores everything to normal. It may be necessary to call the menu function "Update all components" in the Firmware update dialog's Options menu. This scenario only results in permanent damage in the most rare cases, and it is very worthwhile to repeat the procedure before sending a device in for repair.
- Behaviour under error condition, Windows cuts off the network connection without the user's knowledge; but this can be prevented using the PC's Control Panel.
Background: During the firmware updates there is no data transfer for a few minutes and thus no network activity; Windows detects inactivity of the connection and the following mechanisms are set in motion:
 - a) Windows' energy saving mode switches the LAN adapter off, consequently interrupting the network connection!
 - b) Windows switches to the next LAN adapter if there is one (some PCs have multiple adapters in order to, for instance, to access services in parallel that are accessible via separate networks.)
 - c) Other scenarios are feasible, e.g. if switches are activated, which can also respond to missing data traffic.

If an error message is posted during the firmware update, leave the device on and contact our [tech support](#). The firmware update may be continued with guidance from the tech support.

**Note****Firmware logbook**

The "*File*" menu offers a function for working with the firmware log file. Every action taken during a firmware update plus any errors which may occur are recorded in a log file. This log file can be displayed with menu "*File*" > "*Show log file*".

Update all components

The "*Options*" menu offers the option to "*Update all components*". This makes it possible to earmark all the components of the selected device for an update. The function is only to be used in compliance with instructions from the tech support.

6 Pin configuration

6.1 DSUB-15 pin configuration

The **Standard plug** is a 1:1 DSUB-15 to screw terminal adapter. It can be used for all modules which come with the corresponding pin configuration.

The **Special plugs** do not offer direct adaption from the DSUB pins to the screw terminals, but instead come with extra functions:

- For current measurement (up to 50 mA) with voltage channels the **Shunt plug** (ACC/DSUBM-I2 and I4) have a built-in 50 Ω shunt. The scaling factor 0.02 A/V must be set in order to display the current value.
- For temperature measurements, a special, patented **Thermo plug** (ACC/DSUBM-T4) is available. This DSUB-15 plug is suited for measurement of voltages as well as temperatures with PT100 and thermocouples with integrated cold junction compensation (CJC). Any types of thermocouples can be connected at the differential inputs (+IN and -IN). It also has additional "auxiliary contacts" for connecting PT100 in 4-wire configurations, where the reference current loop is already pre-wired internally. The Thermo plug can also be used for normal voltage measurement.
- The **IEPE/ICP plug** (ACC/DSUB-ICP2 and ICP4) provide a current supply source as well as a capacitive coupling.
- The **TEDS plugs** store sensor information according to IEEE1451.4 for use with imc Plug & Measure (integrated TEDS chips DS 2433).

Note

The screw terminals of the plug

- To connect the measurement leads with the screw terminals, suitable leads should have a maximum cross section of 1.5 mm² incl. cable end-sleeve.
- The terminals' screw heads only have secure electrical contact once they are tightened to a connection wire. For this reason, a control measurement (for instance with multimeter probe tips) at "open" terminals can falsely mimic a missing contact!
- Cable shielding must be connected at CHASSIS (DSUB frame) as a rule. At some plugs, V_{CC} (5 V) is available, with a maximum load current of typically 135 mA per plug.

In general: DSUB pin 1 is internally reserved.

6.1.1 Universal plug

Metal plug

ACC/DSUBM-		UNI2
DSUB Pin	Terminal	UNIVERSAL
9	1	+VB1
3	2	-VB1
2	3	+IN1
10	4	-IN1
11	5	I1_1/4B1 ⁽¹⁾
4	6	-SENSE1
5	7	+IN2
13	8	-IN2
14	9	I2_1/4B2 ⁽¹⁾
7	10	-SENSE2
12	11	+VB2
6	12	-VB2
15	15	(GND)
8	18	(+5V)
	13	
	14	
⊕	16	CHASSIS
⊕	17	CHASSIS

The abbreviation "VB" stands for the bridge sensor supply and can be equated with the sensor supply, abbreviation: SUPPLY.

(1) if the special version of the amplifier is equipped with the ±15 V option, then this pin = -15 V

6.1.2 Standard plug

Metal plug

ACC/DSUBM-		B2	U4
DSUB Pin	Terminal	BRIDGE	VOLTAGE
9	1	+VB1	(RES.)
2	2	+IN1	+IN1
10	3	-IN1	-IN1
3	4	-VB1	(+SUPPLY)
11	5	[+SENSE1_1/4B1]	+IN2
4	6	-SENSE1	-IN2
12	7	+VB2	(-SUPPLY)
5	8	+IN2	+IN3
13	9	-IN2	-IN3
6	10	-VB2	(GND) *
14	11	[+SENSE2_1/4B2]	+IN4
7	12	-SENSE2	-IN4
15	15	GND	(GND)
8	18	+5V	(+5V)
	13		
	14		
⊕	16	CHASSIS	CHASSIS
⊕	17	CHASSIS	CHASSIS

[] : 1/4 Bridge with UNI2-8 and DCB2-8

* if special version with ±15 V option, then this pin 6 is the reference

In general: DSUB pin 1 is internally reserved.

Metal plug

ACC/DSUBM-		ENC4, ENC4-IU	FRQ2	DI4-8	DO-8	DAC4
DSUB Pin	Terminal	INC.-ENCODER	FREQUENCY	DIGITAL IN	DIGITAL OUT	ANALOG OUT
9	1	+INA	+IN1	+IN1	BIT1	
2	2	-INA	-IN1	+IN2	BIT2	DAC1
10	3	+INB		+IN3	BIT3	AGND
3	4	-INB		+IN4	BIT4	
11	5	+INC	+IN2	-IN1/2/3/4	BIT5	DAC2
4	6	-INC	-IN2	+IN5	BIT6	AGND
12	7	+IND		+IN6	BIT7	
5	8	-IND		+IN7	BIT8	DAC3
13	9	+INDEX		+IN8		AGND
6	10	-INDEX		-IN5/6/7/8		
14	11	+5V	+5V	+HCOM	HCOM	DAC4
7	12	GND *	GND	LCOM	LCOM	AGND
15	15	(-SUPPLY)		LCOM	LCOM	
8	18	(+SUPPLY)		LEVEL	OPDRN	
	13					
	14					
⊕	16	CHASSIS	CHASSIS	CHASSIS	CHASSIS	CHASSIS
⊕	17	CHASSIS	CHASSIS	CHASSIS	CHASSIS	CHASSIS

* if special version with ±15 V option, then this pin is reference

With HRENC-4 the INDEX channel is only on the first socket (CON1) available; with ENC-4: INDEX only on second socket (CON2)

6.1.3 Special plug

Metal plug

ACC/DSUBM-		T4
DSUB Pin	Terminal	TH-COUPLE/RTD
9	1	+I1
3	2	(+SUPPLY)
2	3	+IN1
10	4	-IN1
11	5	+IN2
4	6	-IN2
5	7	+IN3
13	8	-IN3
14	9	+IN4
7	10	-IN4
12	11	(-SUPPLY)
6	12	-I4 (GND) *
	15	-I3
	18	+I2
15	13	GND
	14	+I3
	16	+I4
	17	-I1
	19	-I2
	20	CHASSIS

Metal plug

ACC/DSUBM-		I4	I2
DSUB Pin	Terminal	CURRENT	CURRENT
9	1	(RES.)	+SUPPLY1
2	2	+IN1	+IN1
10	3	-IN1	-IN1
3	4	(+SUPPLY)	-SUPPLY1
11	5	+IN2	
4	6	-IN2	
12	7	(-SUPPLY)	+SUPPLY2
5	8	+IN3	+IN2
13	9	-IN3	-IN2
6	10	(GND)	-SUPPLY2
14	11	+IN4	
7	12	-IN4	
15	15	(GND)	(GND)
8	18	(+5V)	(+5V)
	13		
	14		
⊕	16	CHASSIS	CHASSIS
⊕	17	CHASSIS	CHASSIS

DSUB-Terminal	ICP4	ICP2
1	+ICP1	+ICP1
2	-ICP1	-ICP1
3	+ICP2	
4	-ICP2	
5	+ICP3	+ICP2
6	-ICP3	-ICP2
7	+ICP4	
8	-ICP4	
9		
10		
11		
12		
13		
14	CHASSIS	CHASSIS
15	CHASSIS	CHASSIS
16	CHASSIS	CHASSIS
17	+5V	+5V
18	AGND	AGND

* if the special version of the amplifier is equipped with the ±15 V option, then this pin 6 is the reference

6.1.4 TEDS plug

ACC/DSUBM-TEDS-	UNI2	
DSUB Pin	Terminal	UNIVERSAL
9	1	+VB1
3	2	-VB1
2	3	+IN1
10	4	-IN1
11	5	I1_1/4B1 ⁽¹⁾
4	6	-SENSE1
5	7	+IN2
13	8	-IN2
14	9	I2_1/4B2 ⁽¹⁾
7	10	-SENSE2
12	11	+VB2
6	12	-VB2
15	15	TEDS_GND
8	18	(+5V)
	13	TEDS2
	14	TEDS1
⊕	16	CHASSIS
⊕	17	CHASSIS

ACC/DSUBM-TEDS-	B2	U4
DSUB Pin	BRIDGE	VOLTAGE
9	+VB1	(RES.)
2	+IN1	+IN1
10	-IN1	-IN1
3	-VB1	(+SUPPLY)
11	[+SENSE1_1/4B1]	+IN2
4	-SENSE1	-IN2
12	+VB2	(-SUPPLY)
5	+IN2	+IN3
13	-IN2	-IN3
6	-VB2	GND ⁽²⁾
14	[+SENSE2_1/4B2]	+IN4
7	-SENSE2	-IN4
15	(GND), TEDS_GND	TEDS_GND
8	(+5V)	(+5V)
	13	TEDS1
	14	TEDS2
⊕	16	CHASSIS
⊕	17	CHASSIS
	19	TEDS3
	20	TEDS4

(1) if the special version of the amplifier is equipped with the ±15 V option, then this pin = -15 V

(2) if special version with ±15 V option, then this pin 6 is the reference

[] : 1/4 Bridge with UNI2-8 and DCB2-8

ACC/DSUBM-TEDS-	T4	
DSUB	Terminal	TH-COUPLE/RTD
2	3	+IN1
3	2	(+SUPPLY)
4	6	-IN2
5	7	+IN3
6	12	-I4
7	10	-IN4
8		reserved
9	1	+I1
10	4	-IN1
11	5	+IN2
12	11	(-SUPPLY)
13	8	-IN3
14	9	+IN4
15	13	TEDS_GND
	14	+I3
	15	-I3
	16	+I4
	17	TEDS3
	18	TEDS4
	19	TEDS2
	20	TEDS1
	21	-I1
	22	+I2
	23	-I2
⊕	24	CHASSIS

ACC/DSUBM-TEDS-	I4	I2
DSUB Pin	CURRENT	CURRENT
2	+IN1	+IN1
3	(+SUPPLY)	-SUPPLY1
4	-IN2	
5	+IN3	+IN2
6	GND	-SUPPLY2
7	-IN4	
8	(+5V)	(+5V)
9	(RES.)	+SUPPLY1
10	-IN1	-IN1
11	+IN2	
12	(-SUPPLY)	+SUPPLY2
13	-IN3	-IN2
14	+IN4	
15	TEDS_GND	TEDS_GND
	13	TEDS1
	14	TEDS2
⊕	16	CHASSIS
⊕	17	CHASSIS
	19	TEDS3
	20	TEDS4

6.2 DSUB-26 pin configuration (High Density)

ACC/DSUBM-		HD-I4	HD-B4
DSUB	Klemme	CURRENT	BRIDGE
13	1	+IN2	+IN2
4	2	-IN2	-IN2
14	3		[+SENSE2_1/4B2]
5	4		-SENSE2
15	5	+IN3	+IN3
6	6	-IN3	-IN3
16	7		[+SENSE3_1/4B3]
7	8		-SENSE3
23	9	+SUPPLY3	+VB3
24	10	-SUPPLY3	-VB3
25	11	+SUPPLY4	+VB4
26	12	-SUPPLY4	-VB4
17	13	+IN4	+IN4
8	14	-IN4	-IN4
18	15		[+SENSE4_1/4B4]
9	16		-SENSE4
21	17	+SUPPLY2	+VB2
22	18	-SUPPLY2	-VB2
19	19	+SUPPLY1	+VB1
20	20	-SUPPLY1	-VB1
11	21	+IN1	+IN1
2	22	-IN1	-IN1
12	23		[+SENSE1_1/4B1]
3	24		-SENSE1

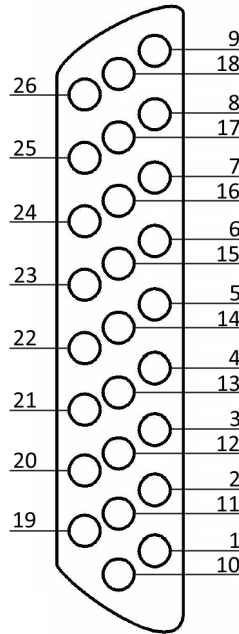

Please use the screw for a contact with Chassis.

6.3 DSUB-37 pin configuration

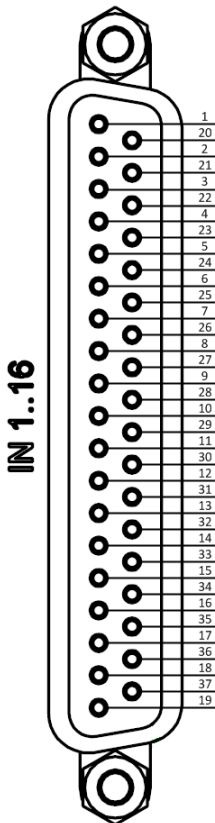

Pin	Signal	Pin	Signal	Pin	Signal
1	+IN1	13	+IN13	25	-IN6
2	+IN2	14	+IN14	26	-IN7
3	+IN3	15	+IN15	27	-IN8
4	+IN4	16	+IN16	28	-IN9
5	+IN5	17	+SUPPLY*)	29	-IN10
6	+IN6	18	0V	30	-IN11
7	+IN7	19	GND*)	31	-IN12
8	+IN8	20	-IN1	32	-IN13
9	+IN9	21	-IN2	33	-IN14
10	+IN10	22	-IN3	34	-IN15
11	+IN11	23	-IN4	35	-IN16
12	+IN12	24	-IN5	36	-SUPPLY*)
				37	+5V

*) not connected for variant without Supply.

Pin 18 (0V) is reference for +5V.

Pin 19 (GND) is reference for bipolar Supply.

6.4 LEMO pin configuration

6.4.1 LEMO.1B (7-pin)

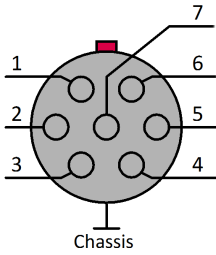

LEMO PIN	ISO2-8	ISOF-8 (± 15 V, bipolar)	LV3-8	LV3-8-L-SUPPLY
1	+IN	+IN	+IN	+IN
2	-IN	-IN	-IN	-IN
3	+SUPPLY *	+SUPPLY	+SUPPLY	+SUPPLY
4	GND (-SUPPLY)	GND (-SUPPLY, -15 V)	-SUPPLY (GND)	SUPPLY GND
5	TEDS OneWire	TEDS OneWire (SUPPLY GND) TEDS is omitted with ± 15 V option	TEDS OneWire	TEDS OneWire
6	PT100 current source	PT100 current source	n.c.	-SUPPLY (-15 V)
7	+I (pos. signal input for current measurement)	+I (pos. signal input for current measurement)	n.c.	n.c.

LEMO PIN	DCB2-8, B-8	UNI2-8	UNI-4	BR2-4 **
1	+IN	+IN	+IN	+IN
2	-IN	-IN	-IN	-IN
3	+SUPPLY	+SUPPLY	+SUPPLY	+SUPPLY
4	-SUPPLY (GND)	-SUPPLY (GND)	-SUPPLY (GND)	-SUPPLY
5	TEDS (OneWire)	TEDS (OneWire)	TEDS (OneWire)	
6	SENSE	SENSE/Pt100 current source	-SENSE	-SENSE
7	quarter bridge completion	quarter bridge completion / sense for PT100 3-wire configuration	+SENSE_1/4B	+SENSE

LEMO PIN	ENC-4, HRENC-4 ***
1	+IN X
2	-IN X
3	SUPPLY
4	-SUPPLY (GND)
5	+INDEX
6	+IN Y
7	-IN Y

sensor supply voltages available via the optional sensor supply module, see data sheet

* Default ranges: +5 V to +24 V

** Upon request BR2-4 with TEDS - then with 8-pin LEMO (because -SUPPLY is not GND and is also not TEDS-GND)

*** Reference of +INDEX is -SUPPLY (GND)

sensor supply voltage 5 VDC/ 100 mA (optional 300 mA)

other sensor supply voltages available via the optional sensor supply module

An isolated SUPPLY is not supported for modules with LEMO terminal connection: ISO2-8, LV3-8.

LEMO.1B (7-pin)

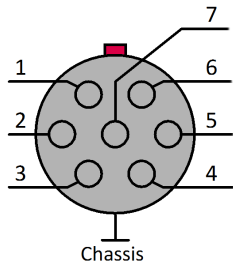

LEMO PIN	AUDIO2-4-MIC	SEN-SUPPLY-4	
1	reserved	+OUT	signal from the sensor, passed through to the amplifier
2	-IN / TEDS-Masse	-OUT	reference for the signal
3	polarization voltage	n.c.	pin 6 and 7 = n.c.
4	+IN	TEDS GND	reference for TEDS
5	TEDS	TEDS	scaling information, for analysis by TEDS-capable amplifiers
6	positive sensor supply		
7	negative sensor supply		
housing	device ground		

6.4.2 LEMO.1B (4-pin)

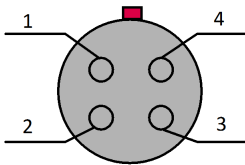

LEMO PIN	CRFX HANDLE POWER
1	50 V
2	GND
3 and 4	reserved

LEMO.1B.304 (additional output supply socket)

6.4.3 LEMO.1E (6-pin), WFT-2

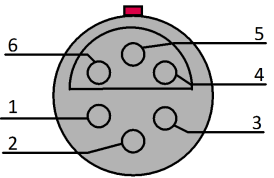

view on the plug of the cable

LEMO PIN	Signal
1	Command OUT
2	12 V POWER
3	Data OUT (normal)
4	Data OUT (invers)
5 and 6	GND

connection cable (H-CAB-LEM-WFT-xm: 6 m or 12 m cable length) between wheel force transducer and CRFX/WFT-2 module.

Reference

[WFT-documentation](#)

A separate documentation describes setup and operation of the measurement wheel.

6.4.4 LEMO.1S (3-pin), ACI-8

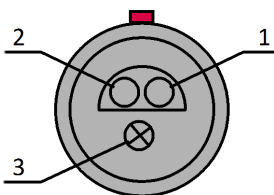

LEMO PIN	ACI-8
1	-IN X
2	+IN X
3	reserved

6.4.5 LEMO.1P (5-pin), HISO-8-L

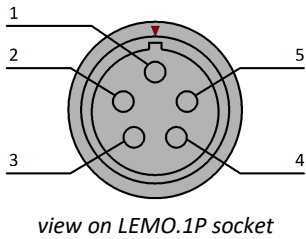

LEMO PIN	HISO-8-L
1	+IN
2	-IN
3	+I
4	+PT
5	-PT

6.4.6 LEMO.2P (2-pin), HISO-8-T-8L

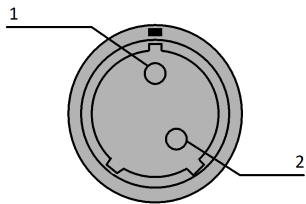

PIN	HISO-8-T-8L	Material
1	+IN	NiCr
2	-IN	Ni

6.4.7 LEMO.2P (8-pin), HISO-8-T-2L

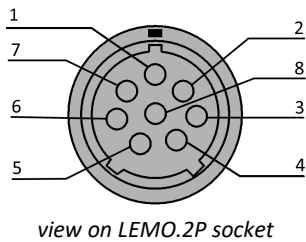

PIN	IN1..4 / Material	IN5..8 / material
1	+IN1 / NiCr	+IN5 / NiCr
2	-IN1 / Ni	-IN5 / Ni
3	+IN2 / NiCr	+IN6 / NiCr
4	-IN2 / Ni	-IN6 / Ni
5	+IN3 / NiCr	+IN7 / NiCr
6	-IN3 / Ni	-IN7 / Ni
7	+IN4 / NiCr	+IN8 / NiCr
8	-IN4 / Ni	-IN8 / Ni

Note

Manufacture of measuring cables

To ensure that the working voltages specified for the channel isolation are reliably maintained, the cores must not be stripped too far during the manufacture of the measuring cables. The isolation of the cores must reach up to the solder cups. For a shielded cable, the exposed cable shield must be completely removed. As a rule, only suitable cables with sufficient isolation should be used.

6.4.8 REMOTE plug (female)

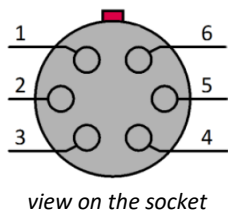

description: [remote control](#)

PIN	CRFX-400 / CRFX-2000 CRFX/HANDLE-POWER	CRFX/HANDLE-UPS-L CRFX/HANDLE-LI-IO-L
1	ON / OFF	ON / OFF
2	SWITCH1	SWITCH1
3	ON / OFF	ON / OFF
4	SWITCH	SWITCH
5	n.c.	REFERENCE (for MUTE)
6	housing	MUTE

6.5 DSUB-9 pin configuration

6.5.1 Display

DSUB-PIN	Signal	description	use in device
1	DCD	Vcc 5 V	connected
2	RXD	Receive Data	connected
3	TXD	Transmit Data	connected
4	DTR	5 V	connected
5	GND	Ground	connected
6	DSR	Data Set Ready	connected
7	RTS	Ready To Send	connected
8	CTS	Clear To Send	connected
9	R1	Pulldown to GND	connected

Supply for the graphical display

plug	+9 V to 32 V	-(0 V)	nc
Binder	1	2	3
Souriau	B	C	A

6.5.2 GPS receiver

With the following wiring, a Garmin GPS-mouse can be connected:

DSUB-9		GPS 18 LVC	GPS 18 - 5Hz
Pin	Signal	Color	Color
1	Vin	Red	Red
2	RxD1*	White	White
3	TxD1	Green	Green
4	-	-	-
5	GND, PowerOff	2x Black	2x Black
6	-	-	-
7	PPS (1 Hz clock)	Yellow	Yellow
8	-	-	-
9	-	-	-

* Pin configuration at measurement device. At the GPS-mouse Rx and Tx are interchanged.

6.5.3 SEN-SUPPLY-4

Pin	Signal	Remarks
1	-IN	signal from the sensor
2	TEDS GND	reference for TEDS (no connection with GND)
3	n.c.	reserved
4	GND	reference for supply voltage ±SUPPLY
5	-SUPPLY	-15 V: supply line to sensor
6	+IN	signal from sensor
7	TEDS	TEDS-memory in the DSUB-9 plug
8	FAIL	sensor status: connection to GND = OK
9	+SUPPLY	+15 V: power supply to sensor

6.5.4 APPMOD

RS 232

Signal	PIN
n.c.	1
RX	2
TX	3
n.c.	4
DG	5
n.c.	6
RTS	7
CTS	8
n.c.	9

RS 422 / RS 485 Full-Duplex

Signal	PIN
Rx+	2
Rx-	8
TX+	3
Tx-	7

RS 485 Half-Duplex

Signal	PIN
+D	3
-D	7

6.5.5 CAN, CAN FD

DSUB-PIN	Signal	Description	Use in device
1	nc	reserved	do not connect
2	CAN_L	dominant low bus line	connected
3	CAN_GND	CAN Ground	connected
4	nc	reserved	do not connect
5	nc	reserved	do not connect
6	CAN_GND	optional CAN Ground	connected
7	CAN_H	dominant high bus line	connected
8	nc	reserved (error line)	do not connect
9	nc	reserved	do not connect

6.5.6 LIN-Bus

DSUB-PIN	Signal	Description
3	LIN_GND	LIN Ground
6	LIN_GND	Optional LIN Ground
7	LIN_INPUT/OUTPUT	LIN bus line
1, 2, 4, 5, 8 and 9	n.c.	

6.5.7 PROFIBUS

DSUB-PIN	Signal	Description
3	DATA+	B-Line
5	GND	PROFIBUS Ground
8	DATA-	A-Line
1, 2, 4, 6, 7 and 9	n.c.	

6.5.8 FlexRay

imc standard: One DSUB-9 socket with two channels

DSUB-Pin	Signal	Description
1	nc	
2	BM channel A	negative bus line channel A
3	GND	FlexRay ground
4	BM channel B	negative bus line channel B
5	GND	FlexRay ground
6	nc	
7	BP channel A	positive bus line channel A
8	BP channel B	positive bus line channel B
9	nc	

Option: Two DSUB-9 sockets (CON1 and CON2) with one channel each

DSUB-Pin	CON1	CON2
1	nc	nc
2	BM channel A (negative bus line channel A)	BM channel B (negative bus line channel B)
3	GND	GND
4	nc	nc
5	GND	GND
6	nc	nc
7	BP channel A (positive bus line channel A)	BP channel B (positive bus line channel B)
8	nc	nc
9	nc	nc

6.5.9 MVB-Bus

EMD connection with double assignment

DSUB-PIN	Signal	Description	as Terminator plug
1	A1. Data_P	data line A	jumper to 6
2	A1. Data_N	data line A	jumper to 7
3	n.c.	not connected	
4	B1. Data_P	data line B	jumper to 8
5	B1. Data_N	data line B	jumper to 9
6	Terminator A	internal;	jumper to 1
7	Terminator A	internal	jumper to 2
8	Terminator B	internal	jumper to 4
9	Terminator B	internal	jumper to 5

ESD connection. Standard DSUB-9 plugs are used.

DSUB-PIN	Signal	Description	Termination
1	A. Data_P	data line A	
2	A. Data_N	data line A	
3	NC	not connected	
4	B. Data_P	data line B	
5	B. Data_N	data line B	
6	A.Bus_GND	Ground A	
7	B.Bus_GND	Ground B	
8	A.Bus_5V	5V Supply A	
9	B.Bus_5V	5V Supply B	

Rm = 143 Ω; Ru = Rd = 383 Ω

6.5.10 ARINC

CON 1					
ARINC-Interface with 8 Rx channels			ARINC-Interface with 8 Rx and 4 Tx channels		
DSUB Pin	Signal	Description	DSUB Pin	Signal	Description
Standard 4x Rx			Standard 4x Rx; 2x Tx		
1	Rx1A	receiving channel 1A	1	Rx1A	receiving channel 1A
9	GND	GND	9	Tx1A	sending channel 1A
2	Rx1B	receiving channel 1B	2	Rx1B	receiving channel 1B
10	GND	GND	10	Tx1B	sending channel 1B
3	Rx2A	receiving channel 2A	3	Rx2A	receiving channel 2A
11	GND	GND	11	GND	GND
4	Rx2B	receiving channel 2B	4	Rx2B	receiving channel 2B
12	GND	GND	12	GND	GND
5	Rx3A	receiving channel 3A	5	Rx3A	receiving channel 3A
13	GND	GND	13	Tx2A	sending channel 2A
6	Rx3B	receiving channel 3B	6	Rx3B	receiving channel 3B
14	GND	GND	14	Tx2B	sending channel 2B
7	Rx4A	receiving channel 4A	7	Rx4A	receiving channel 4A
15	GND	GND	15	GND	GND
8	Rx4B	receiving channel 4B	8	Rx4B	receiving channel 4B

CON 2					
ARINC-Interface with 8 Rx channels			ARINC-Interface with 8 Rx and 4 Tx channels		
DSUB Pin	Signal	Description	DSUB Pin	Signal	Description
Standard 4x Rx			Standard 4x Rx; 2x Tx		
1	Rx5A	receiving channel 5A	1	Rx5A	receiving channel 5A
9	GND	GND	9	Tx3A	sending channel 3A
2	Rx5B	receiving channel 5B	2	Rx5B	receiving channel 5B
10	GND	GND	10	Tx3B	sending channel 3B
3	Rx6A	receiving channel 6A	3	Rx6A	receiving channel 6A
11	GND	GND	11	GND	GND
4	Rx6B	receiving channel 6B	4	Rx6B	receiving channel 6B
12	GND	GND	12	GND	GND
5	Rx7A	receiving channel 7A	5	Rx7A	receiving channel 7A
13	GND	GND	13	Tx4A	sending channel 4A
6	Rx7B	receiving channel 7B	6	Rx7B	receiving channel 7B
14	GND	GND	14	Tx4B	sending channel 4B
7	Rx8A	receiving channel 8A	7	Rx8A	receiving channel 8A
15	GND	GND	15	GND	GND
8	Rx8B	receiving channel 8B	8	Rx8B	receiving channel 8B

6.6 PROFINET

Pin configuration of the network socket type modular 8P8C	Pin	Signal
	1	TX+
2	TX-	
3	RX+	
6	RX-	
4, 5, 7, 8	via RC to ground	



6.7 EtherCAT

CRFX modules are connected as load to be supplied to all 8 wires of the network cable, i.e. both the 4 data lines and the 4 additional free wires. In this sense (a redundant use of data and free lines) the concept is PoEC compliant – i.e. also to standard PoEC Power-Injectors.

M8 socket		RJ45 socket	
Pin	Signal	Pin	Signal
1	+TxD	1	+TxD
2	+RxD	2	-TxD
3	-TxD	3	+RxD
4	-RxD	6	-RxD
		4, 5, 7, 8	unused

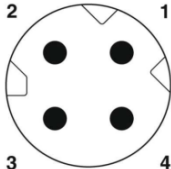

M8 socket, D-coded
(view on top of the stitches)
e.g. imc CRONOS-XT base (CRXT)

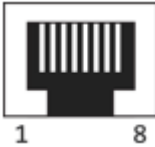

view on top of the RJ45 socket

Note

imc CRONOSflex (CRFX) Base Unit

The CRFX base, as the power master, **feeds only on the free wires**.
We recommend a separate transmission of data and voltage, i.e. the use of all 8 pins.

FAQ

Are all 8 pins to be used?

No, not in every case: to supply the CRFX module the 4 data pins are sufficient, for example if a power injector is used.

Yes, if a CRFX base is used as power source.

How can I prevent the transmission of Power over EtherCAT?

Use a four-wire RJ45 cable with only pins 1,2,3 and 6 connected. This way the passive PoE is not transmitted.

Index

A

ACC/DSUB-ICP2 58
 ACC/DSUB-ICP4 58
 ACC/DSUBM-B2 57
 ACC/DSUBM-I2 58
 ACC/DSUBM-I4 58
 ACC/DSUBM-T4 58
 ACC/DSUBM-U4 57
 ACC/DSUBM-UNI2 57
 Accessing the data carrier
 Error 30
 Add device 52
 Add device interface 25
 Adding a device (Add) 25
 adjustment 6
 ARINC
 Pin configuration 68
 ARINC-Bus pin configuration 68

B

Base-Unit 18
 blink code 45
 building block principle 18

C

Cables 8
 calibration 6
 CAN
 Pin configuration 65
 Power via CAN 65
 CAN-Bus pin configuration 65
 CE 8
 CE Certification 6
 Certificates 6
 CF card (Compact Flash) 23
 CFast Storage medium 23
 Change requests 6
 click 18
 Compact Flash 23
 conditioner block 38
 connect device 50
 Connecting via LAN 50
 Copy data to the PC 24
 CRFX/ECAT-GATEWAY 46
 CRFX-HANDLE-LI-IO-L 39
 CRFX-HANDLE-POWER 39
 CRFX-HANDLE-UPS-L 39
 CRONOSflex 18

Customer support
 Tech support 6

D

data acquisition 18
 Data transfer 24
 FTP access 26
 Storage medium 24
 decentralized satellite modules 21
 Device
 add 52
 connect 50
 Device: Remote control 21
 DIN-EN-ISO-9001 6
 directly stacked modules 37
 Display
 Pin configuration 64
 distributed blocks 38
 distributed measurement system 19
 Distributed system 18
 DSUB-26
 Pin configuration 60
 DSUB-9
 SEN-SUPPLY-4 64

E

ElektroG 8
 EMC 7
 energy sources 10
 EtherCAT
 Gateway 46
 IN 45
 M8 69
 OUT 45
 Pin configuration 69
 RJ45 69
 EtherCAT Gateway 46
 EtherCAT standard 18
 ExpressCard Storage medium 23
 Extension for Windows-Explorer 24

F

FCC 8
 File system FAT16/FAT32 27
 Filesize (maximum) 27
 Firmware update 53
 Logbook 55
 FlexRay
 Pin configuration 66
 FLEXRAY pin configuration 66
 forced grounding via AC/DC adapter's safety ground 34

formatting 27

FTP access

Data transfer 26

G

Gateway 46

General terms and conditions 6

GPS receiver

Pin configuration 64

ground differentials 34

Grounding concept 34

Guarantee 6, 7

H

Hard drive 21

Hotline

Tech support 6

Hot-Plug

FTP access 26

Storage medium 22

I

imc Systems 24, 25

formatting 27

imc STUDIO 49

operating system 49

IN: EtherCAT 45

Industrial safety 12

Industrial safety regulation 12

Installation

imc STUDIO 49

internal data storage 30

Internal storage media 21

IP address

configure 50

of the devices 50

of the PCs 50

ISO-9001 6

ISOF-16-D37 60

isolated power input 34

Isolation 33

Issues

Storage medium 30

L

Leads 8

LEMO plug

ACI-8 62

BR2-4 61

DCB2-8 61

HRENC-4 61

ISO2-8 61

ISOF-8 61

LV3-8 61

Pin configuration 61

UNI2-8 61

UNI-4 61

LEMO.1P (5-pin)

HISO-8-L 63

pin configuration 63

LEMO.1S

ACI-8 62

pin configuration 62

LEMO.2P (2-pin)

HISO-8-T-8L 63

pin configuration 63

LEMO.2P (8-pin)

HISO-8-T-2L 63

pin configuration 63

Liability restrictions 7

Li-ion battery

Technical Specs 31

LIMIT 39

Limitations

Storage medium 30

Limited Warranty 6

LIN

Pin configuration 65

LIN-Bus pin configuration 65

Logbook

Firmware update 55

M

Main switch 21

maintenance 6

Memory card 21

Mounting CRONOSflex Modules 16

MVB EMD, ESD

Pin configuration 67

N

network cable 18

Networking and power supply 35

O

Operating personnel 11

OUT: EtherCAT 45

overview FLEX modules 44

overview power supply options 35

P

partition 27

Pin configuration

- ARINC 68
- CAN 65
- Display 64
- DSUB-26 60
- FlexRay 66
- GPS receiver 64
- LEMO plug 61, 62
- LEMO.1B.304 62
- LEMO.1P (5-pin) 63
- LEMO.1S 62
- LEMO.2P (2-pin) 63
- LEMO.2P (8-pin) 63
- LIN 65
- MVB EMD, ESD 67
- power supply 19
- PROFIBUS 65
- REMOTE plug 63
- RS 232 65
- RS 422 / RS 485 Full-Duplex 65
- RS 485 Half-Duplex 65
- pin configuration ARINC-Bus 68
- pin configuration CAN-Bus 65
- pin configuration FLEXRAY 66
- pin configuration LIN-Bus 65
- pin configuration PROFIBUS 65
- pin configuration PROFINET 69
- plug-type (female) 19
- plug-type (male) 19
- PoEC 43
- power consumption 44
- Power Handle
 - 50 V output terminals 39
 - Remote 39
 - RJ45 39
 - Terminal connection 39
- POWER LED 39
- power outage 30
- Power over EtherCAT 21, 43
- power supply
 - pin configuration 19
- Power supply options 35
- Power via CAN 65
- Problems
 - Storage medium 30
- Product improvement 6
- PROFIBUS
 - Pin configuration 65
- PROFIBUS pin configuration 65
- PROFINET pin configuration 69

Q

- Quality Management 6

R

- rechargeable batteries
 - Li-ion battery 31
- regulation of the supply configurations 36
- Remote 21
- Remote control 21
- Remote control to switch on device 21
- REMOTE plug
 - Pin configuration 63
- repair 6
- Restriction of Hazardous Substances 8
- RoHS 8

S

- satellites 21
- Select device with explorer 24
- SEN-SUPPLY-4
 - DSUB-9 64
- Service
 - Tech support 6
- service and maintenance 6
- service check 6
- Shell extension 24
- Smart Battery 31
- Software installation 49
- Special hazards 12
- SSD Storage medium 23
- Status LED 45
- storage device
 - formatting 27
 - partition 27
- Storage media 21
- Storage medium
 - CF card 23
 - CFast 23
 - Compact Flash 23
 - Data transfer 24
 - ExpressCard 23
 - FAT16/FAT32 27
 - File system 27
 - Filesize (maximum) 27
 - Hot-Plug 22
 - Issues 30
 - Limitations 30
 - Problems 30
 - SSD 23
 - USB 23

supply of multiple clicked modules 36
supply unit 31
Swapping the storage medium 22
Symbols 9
system bus 18
System bus (CRFX) 18
System requirements 49

T

Tech support 6
Telephone numbers
 Tech support 6
turning on 21

U

USB 21
 supply of storage medium 23
USB storage medium 23

W

Warranty 6
Waste on Electric and Electronic Equipment 8
WEEE
 Restriction of Hazardous Substances 8
WFT
 LEMO pin configuration 62
Windows
 Shell extension 24



An Axiometrix Solutions Brand

Contact imc

Address

imc Test & Measurement GmbH

Voltastr. 5

13355 Berlin

Phone: (Germany): +49 30 467090-0

E-Mail: info@imc-tm.de

Internet: <https://www.imc-tm.com>

Tech support

If you have problems or questions, please contact our tech support:

Phone: (Germany): +49 30 467090-26

E-Mail: hotline@imc-tm.de

Internet: <https://www.imc-tm.com/service-training/>

imc ACADEMY - Training center

The safe handling of measurement devices requires a good knowledge of the system. At our training center, experienced specialists are here to share their knowledge.

E-Mail: schulung@imc-tm.de

Internet: <https://www.imc-tm.com/service-training/imc-academy>

International partners

You will find the contact person responsible for you in our overview list of imc partners:

Internet: <https://www.imc-tm.com/imc-worldwide/>

imc @ Social Media

<https://www.facebook.com/imcTestMeasurement>

<https://www.youtube.com/c/imcTestMeasurementGmbH>

https://twitter.com/imc_de

<https://www.linkedin.com/company/imc-test-&-measurement-gmbh>